



	<b>Form A</b>
Pilot ID	Flight #
<b>CIVA Unlimited Programme4</b>	

No	Symbol	Cat. No.	K	Total K	Grade	Pos	Remarks	Item	K	Grade
1		8.6.1.1 9.4.1.3 9.8.3.4 9.1.3.3 9.4.3.3	11 12 15 6 8	Fig J <b>52</b>	.			Pos.	40	
2		8.4.14.1 9.10.7.4 9.2.4.6	12 17 12	Fig E <b>41</b>	.			Harm.	0	
3		6.2.2.1 9.9.1.4 9.4.5.2	15 15 5	Fig B <b>35</b>	.			Fig K	471	Total K 511
4		6.2.1.1 9.9.1.3 9.9.5.3	15 15 11	Fig C <b>41</b>	.			<b>Penalties</b>		
5		5.3.1.1 9.2.2.4 9.8.1.1 9.10.5.3	18 11 7 13	Fig F <b>49</b>	.			Too Low		
6		1.3.12.1 9.1.4.2 9.1.1.2	21 4 8	additional <b>6</b>	.			Too High		
7		8.6.4.3 9.11.1.5 9.1.5.3 9.9.3.3 9.1.3.5	13 4 6 11 9	Fig D <b>43</b>	.			Interruptions		
8		7.2.3.3 9.1.3.2	6 4	additional <b>6</b>	.			Insertions		
9		5.2.1.3 9.4.1.4 9.1.5.4	18 15 8	Fig H <b>41</b>	.			Trg Violation		
10		7.4.4.2 9.8.3.2 9.1.3.4	17 7 8	Fig I <b>32</b>	.			Wing Rocks		
11		8.5.2.1 9.1.2.2	10 6	additional <b>6</b>	.			Disqual Fig		
12		7.8.1.1 9.1.3.8 9.4.4.2 9.1.4.2 9.4.4.4	20 12 5 4 11	Fig G <b>52</b>	.			Other(note...)		
13		8.5.4.1 9.1.2.2 9.1.3.2	11 6 4	additional <b>6</b>	.			<b>Final Freestyle</b>		
14		8.8.7.2 9.10.1.3 9.1.5.2 9.10.6.3	21 17 4 19	Fig A <b>61</b>	.			Duration	Min	Sec
								<b>Judges Details</b>		
								Signature		
								Name		
								Number		

**Prog A** ..... Pilot  
 ..... A/C



		Form B
Pilot ID	CIVA Unlimited Programme4	
	Flight #	

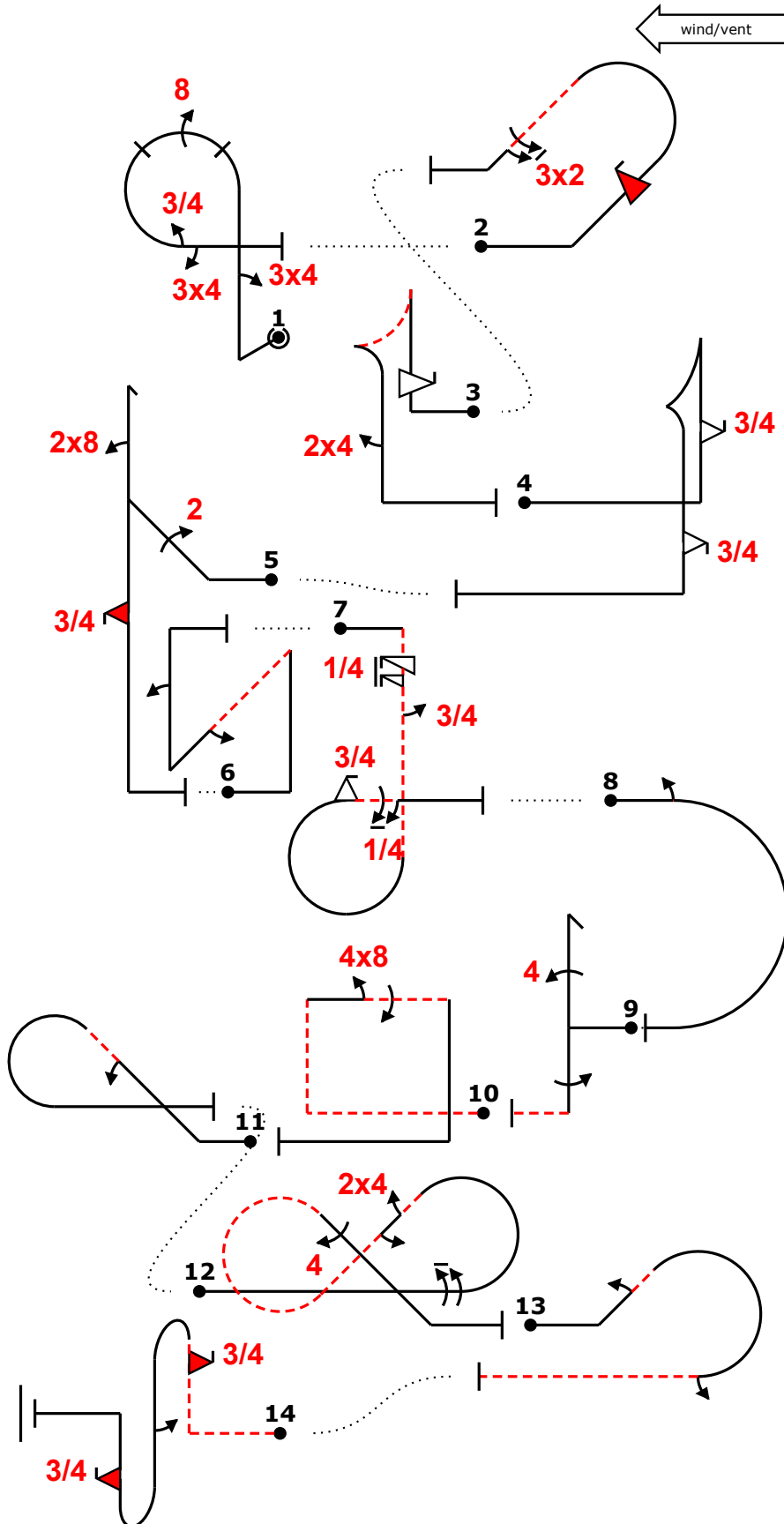

```

ej "0J" .',34rp(,88)3,34 (10,0) "0E" +ifdb32 (7,17) "0B" +,fita`.,24' "0C" --.,3fta3f'+--+ (-9,-1) "0F" ,22dh(8)
.',3if...' (-1,0) "0L" n(2)2 (4,0) "0D" ~,5s,3'irp3f,5 (5,0) "0L" 10% 2a+ (3,0) "0H" 44h1- "0I" -qo48,1 "0L" -2% 2rc
(-5,13) "0G" '9cc(,24,2),44'+ 1% "0L" 2 rc2- (-10,4) "0A" -,3ifbb( 2)3if>
  
```

Prog A ..... Pilot  
 ..... A/C



		Form C
Pilot ID	CIVA Unlimited Programme4	
	Flight #	

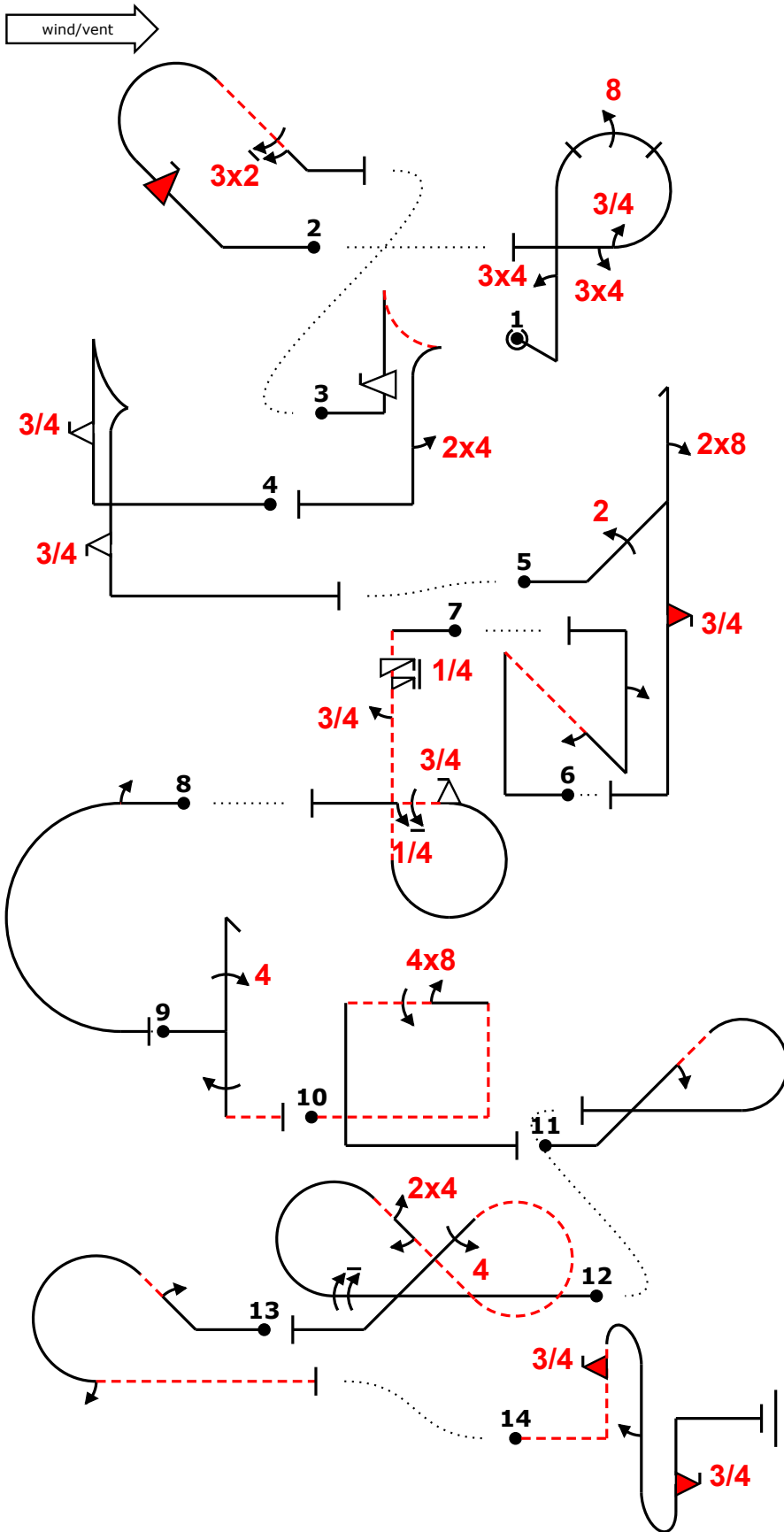

```

ej "@J" .',34rp(,88)3,34 (10,0) "@E" .....+ifdb32 (7,17) "@B" .....+,fita`.,24' " @C" --+.3fta3f'+--+ (-9,-1) "@F" ,22dh(8)
.',3if....' (-1,0) "@L" n(2)2 (4,0) "@D" .....5s,3' irp3f,5 (5,0) "@L" 10% 2a+ (3,0) "@H" 44h1- "@I" -qo48,1 "@L" -2% 2rc
(-5,13) "@G" '9cc(,24,2),44'+ 1% "@L" .....2 rc2- (-10,4) "@A" -,3ifbb( .....2)3if>
  
```

Prog A ..... Pilot  
 ..... A/C



Judges Name		Flight #
Signature	Number	

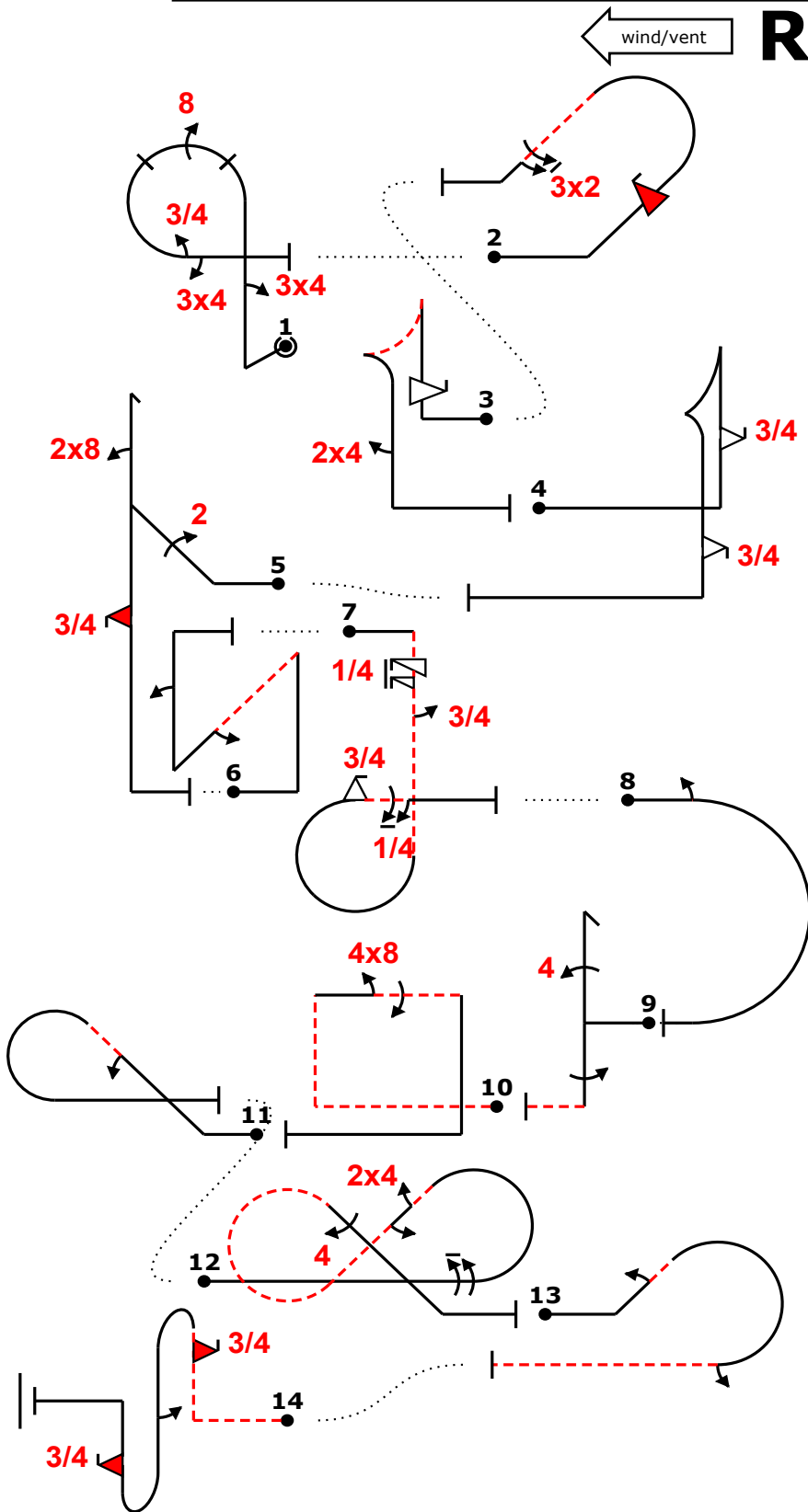

Fig	Grade	Pos	Remarks
1	.		
2	.		
3	.		
4	.		
5	.		
6	.		
7	.		
8	.		
9	.		
10	.		
11	.		
12	.		
13	.		
14	.		

Positioning  
40

Too Low		Trg Violation	
Too High		Wing Rocks	
Interruptions		Disqual Fig	
Insertions		Other(note...)	

```
ej "0J" .,34rp(,88)3,34 (10,0) "0B" ~~~~~+ifdb32 (7,17) "0B" ~~~~~+,fita~~,24" "0C" ~+.,3fta3f'+
+~ (-9,-1) "0F" ~,22dh(8)-.,3if... (-1,0) "0L" n(2)2 (4,0) "0D" ~~~5s,3'irp3f,5 (5,0) "0L" 10% ~
2a+~~ (3,0) "0H" 44h1- "0I" ~go48,1 "0L" ~2% 2rc (-5,13) "0G" '9cc(,24,2),44+~~ 1% "0L" ~~~~~2
~rc2- (-10,4) "0A" ~-,3ifbb(~~~~2)3if>
```

Fig 1 J	K	Fig 2 E	K	Fig 3 B	K	Fig 4 C	K	Fig 5 F	K	Fig 6 L	K	Fig 7 D	K	Fig 8 L	K	Fig 9 H	K	Fig 10 I	K	Fig 11 L	K	Fig 12 G	K	Fig 13 L	K	Fig 14 A	K
8.6.1.1	11	8.4.14.1	12	6.2.2.1	15	6.2.1.1	15	5.3.1.1	18	1.3.12.1	21	8.6.4.3	13	7.2.3.3	6	5.2.1.3	18	7.4.4.2	17	8.5.2.1	10	7.8.1.1	20	8.5.4.1	11	8.8.7.2	21
9.4.1.3	12	9.10.7.4	17	9.9.1.4	15	9.9.1.3	15	9.2.2.4	11	9.1.4.2	4	9.11.1.5	4	9.1.3.2	4	9.4.1.4	15	9.8.3.2	7	9.1.2.2	6	9.1.3.8	12	9.1.2.2	6	9.10.1.3	17
9.8.3.4	15	9.2.4.6	12	9.4.5.2	5	9.9.5.3	11	9.8.1.1	7	9.1.1.2	8	9.1.5.3	6			9.1.5.4	8	9.1.3.4	8			9.4.4.2	5	9.1.3.2	4	9.1.5.2	4
9.1.3.3	6							9.10.5.3	13			9.9.3.3	11									9.1.4.2	4			9.10.6.3	19
9.4.3.3	8											9.1.3.5	9									9.4.4.4	11				
	52		41		35		41		49		6		43		6		41		32		6		52		6		61



Judges Name		Flight #
Signature	Number	

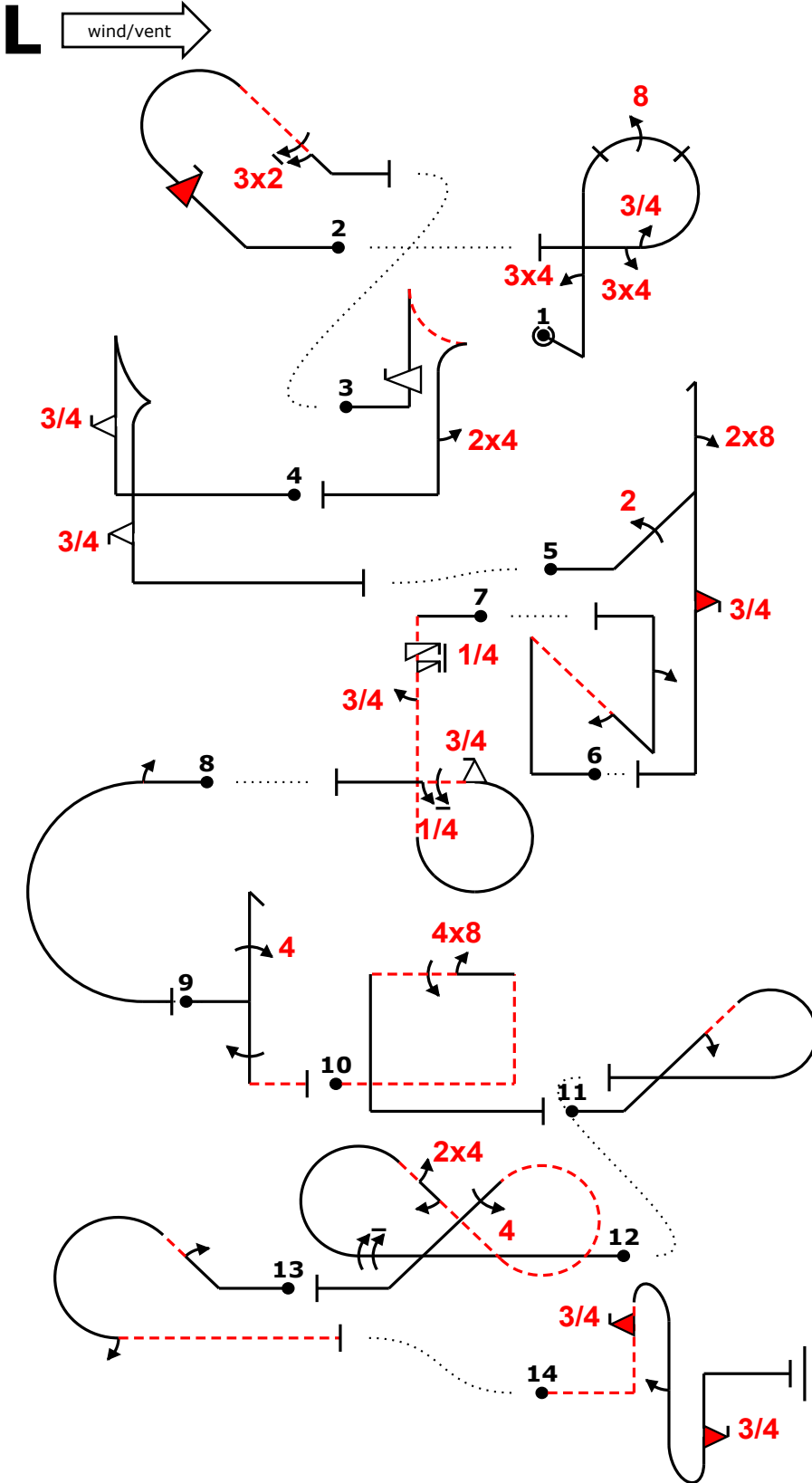

Fig	Grade	Pos	Remarks
1	.		
2	.		
3	.		
4	.		
5	.		
6	.		
7	.		
8	.		
9	.		
10	.		
11	.		
12	.		
13	.		
14	.		

Positioning	.
40	.

Too Low		Trg Violation	
Too High		Wing Rocks	
Interruptions		Disqual Fig	
Insertions		Other(note...)	

```
ej "0J" .',34rp(,88)3,34 (10,0) "0B" ~~~~~+ifdb32 (7,17) "0B" ~~~~~+,fita~~,24" "0C" ~+.,3fta3f'+
+~ (-9,-1) "0F" ,22dh(8)-',3if... (-1,0) "0L" n(2)2 (4,0) "0D" ~~~5s,3'irp3f,5 (5,0) "0L" 10% ~
2a+~~ (3,0) "0H" 44h1- "0I" -go48,1 "0L" -2% 2rc (-5,13) "0G" '9cc(,24,2),44+~~ 1% "0L" ~~~~~2
~~rc2- (-10,4) "0A" -',3ifbb(~~~~2)3if>
```

Fig 1 J	K	Fig 2 E	K	Fig 3 B	K	Fig 4 C	K	Fig 5 F	K	Fig 6 L	K	Fig 7 D	K	Fig 8 L	K	Fig 9 H	K	Fig 10 I	K	Fig 11 L	K	Fig 12 G	K	Fig 13 L	K	Fig 14 A	K
8.6.1.1	11	8.4.14.1	12	6.2.2.1	15	6.2.1.1	15	5.3.1.1	18	1.3.12.1	21	8.6.4.3	13	7.2.3.3	6	5.2.1.3	18	7.4.4.2	17	8.5.2.1	10	7.8.1.1	20	8.5.4.1	11	8.8.7.2	21
9.4.1.3	12	9.10.7.4	17	9.9.1.4	15	9.9.1.3	15	9.2.2.4	11	9.1.4.2	4	9.11.1.5	4	9.1.3.2	4	9.4.1.4	15	9.8.3.2	7	9.1.2.2	6	9.1.3.8	12	9.1.2.2	6	9.10.1.3	17
9.8.3.4	15	9.2.4.6	12	9.4.5.2	5	9.9.5.3	11	9.8.1.1	7	9.1.1.2	8	9.1.5.3	6			9.1.5.4	8	9.1.3.4	8			9.4.4.2	5	9.1.3.2	4	9.1.5.2	4
9.1.3.3	6							9.10.5.3	13			9.9.3.3	11									9.1.4.2	4			9.10.6.3	19
9.4.3.3	8											9.1.3.5	9									9.4.4.4	11				
	52		41		35		41		49		6		43		6		41		32		6		52		6		61

Pilot: Proq A

A/C:

