



CIVA		Form A
Pilot ID	CIVA Unlimited Programme3	Flight #

No	Symbol	Cat. No.	K	Total K	Grade	Pos	Remarks	Item	K	Grade
1		1.2.7.1 9.10.6.3 9.2.4.6	13 19 12	Fig F 44	.			Pos.	40	
2		7.2.1.1 9.1.3.8 9.10.8.4 9.9.8.4	6 12 15 13	Fig B 46	.			Harm.	0	
3		7.4.1.4 9.2.3.8	11 15	Fig C 26	.			Fig K	512	Total K 552
4		7.2.1.4	6	additional 6	.			Penalties		
5		7.4.5.1 9.1.2.5 9.8.2.1 9.9.9.4	15 11 5 13	Fig A 44	.			Too Low		
6		5.3.1.1 9.2.2.4 9.1.1.1 9.4.5.3	18 11 6 8	Fig I 43	.			Too High		
7		8.8.1.1 9.4.1.3 9.10.10.3 9.2.1.4	18 12 15 13	Fig G 58	.			Interruptions		
8		8.6.2.4 9.12.1.4 9.2.5.4 9.4.3.4 9.2.3.6	12 7 9 11 12	Fig J 51	.			Insertions		
9		7.2.3.3 9.1.3.2	6 4	additional 6	.			Trg Violation		
10		7.8.5.1 9.4.2.2 9.10.2.2 9.4.2.3 9.1.2.3 9.8.3.4 9.1.3.4	20 7 15 10 8 15 8	Fig E 83	.			Wing Rocks		
11		5.2.1.1	17	additional 6	.			Disqual Fig		
12		8.6.2.1 9.9.1.4 9.9.3.4 9.1.3.7 9.1.3.5	12 15 11 11 9	Fig D 58	.			Other(note...)		
13		5.2.1.4 9.1.5.2	22 4	additional 6	.			Final Freestyle		
14		8.4.13.1 9.4.2.4 9.4.4.4	11 13 11	Fig H 35	.			Duration	Min	Sec

Judges Details		
Signature		
Name		
Number		

Prog E Pilot
 A/C



		Form B
Pilot ID	CIVA Unlimited Programme3	
	Flight #	

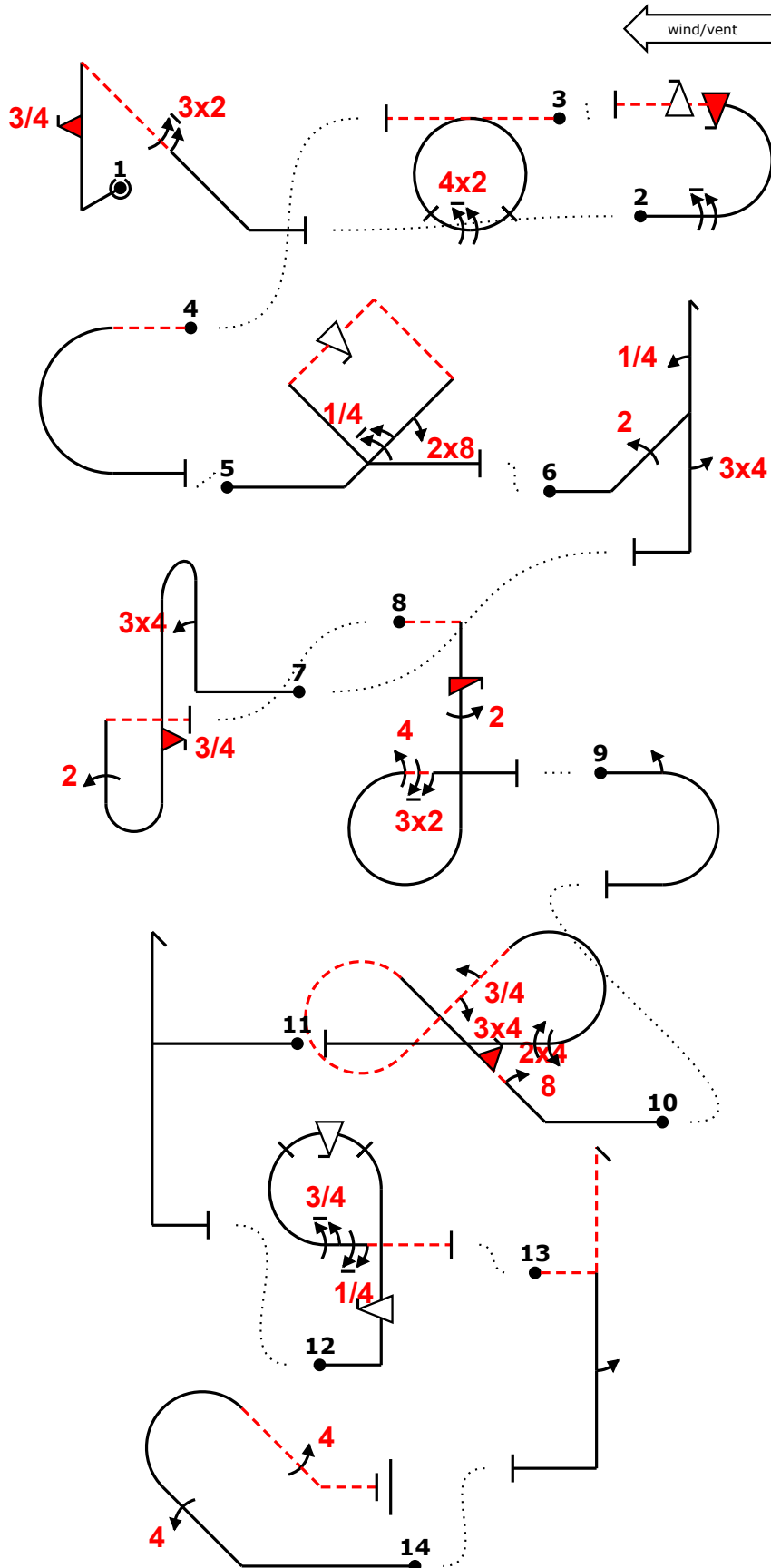

ej "eF" 3ifk32 (20,-1) "@B" 9mif,f- (0,1) "@C" -io42- (-10,15) "@L" 3% -a (-1,1) "@A" 5,8dqf (1,2) "@I" 22dh(4)34.' (-20,10)
 "eG" -34'bb(3if)22- (11,-7) "@J" -is;22irp44,32 (2,0) "@L" 2a (8,17) "@E" ,24;2ifroc(.',34`",|"3`")88,1+` "@L" ++h..' (4
 ,10) "@D" frp(f)7,5- (2,2) "@L" -'h.2.'-- (-3,7) "@H" 44db44-

Prog E
 Pilot
 A/C



		Form C
Pilot ID	CIVA Unlimited Programme3	
	Flight #	

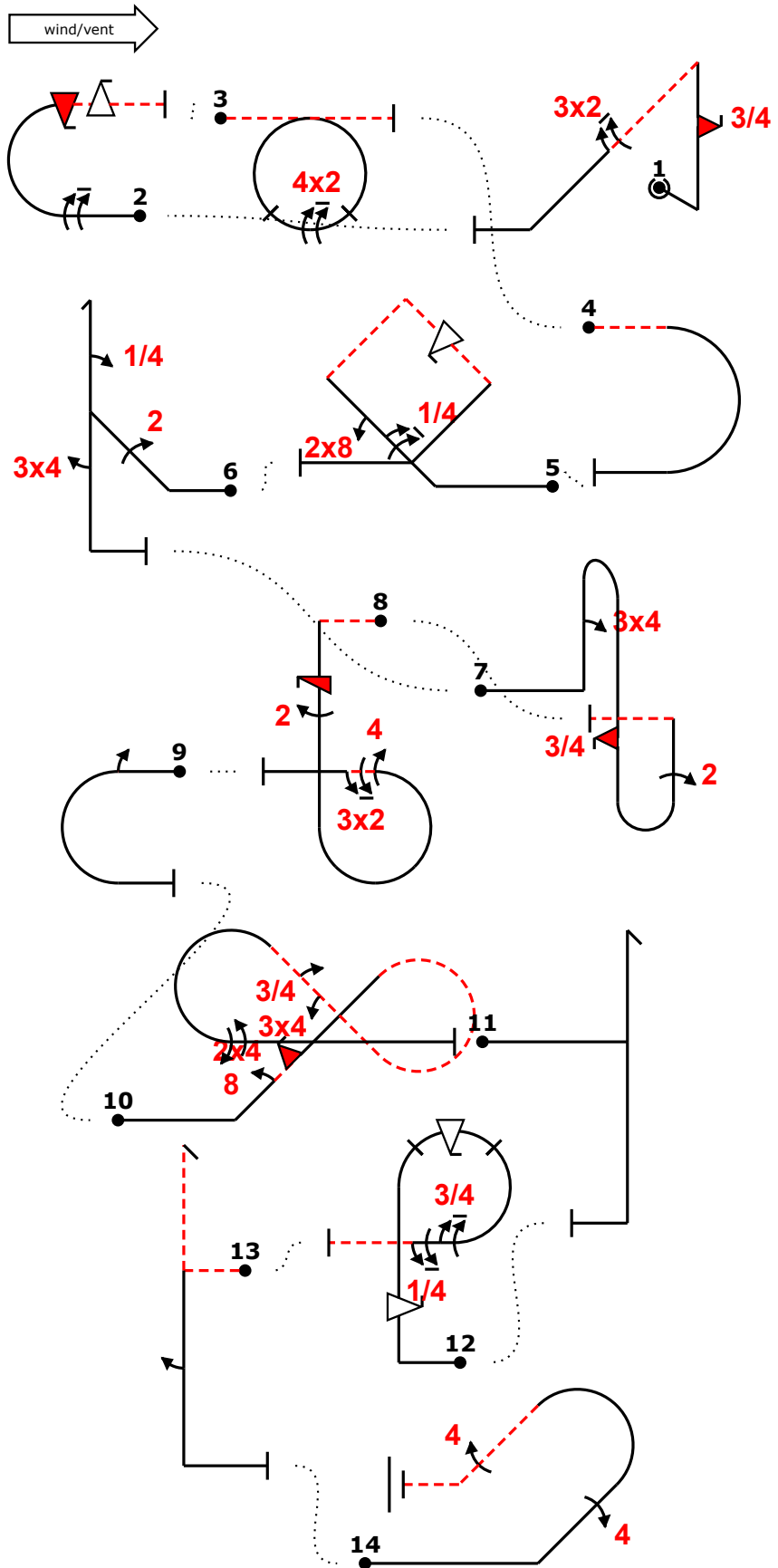

ej "eF" 3ifk32 (20,-1) "@B" 9mif,f- (0,1) "@C" -io42- (-10,15) "@L" 3% -a (-1,1) "@A" 5,8dqf (1,2) "@I" 22dh(4)34.' (-20,10)
 "eG" -34'bb(3if)22- (11,-7) "@J" -is;22irp44,32 (2,0) "@L" 2a (8,17) "@E" ,24;2ifroc(.,34`,"|3`"88,1+` "@L" ++h..' (4
 ,10) "@D" frp(f)7,5- (2,2) "@L" -'h.2.'-- (-3,7) "@H" 44db44-

Prog E Pilot
 A/C

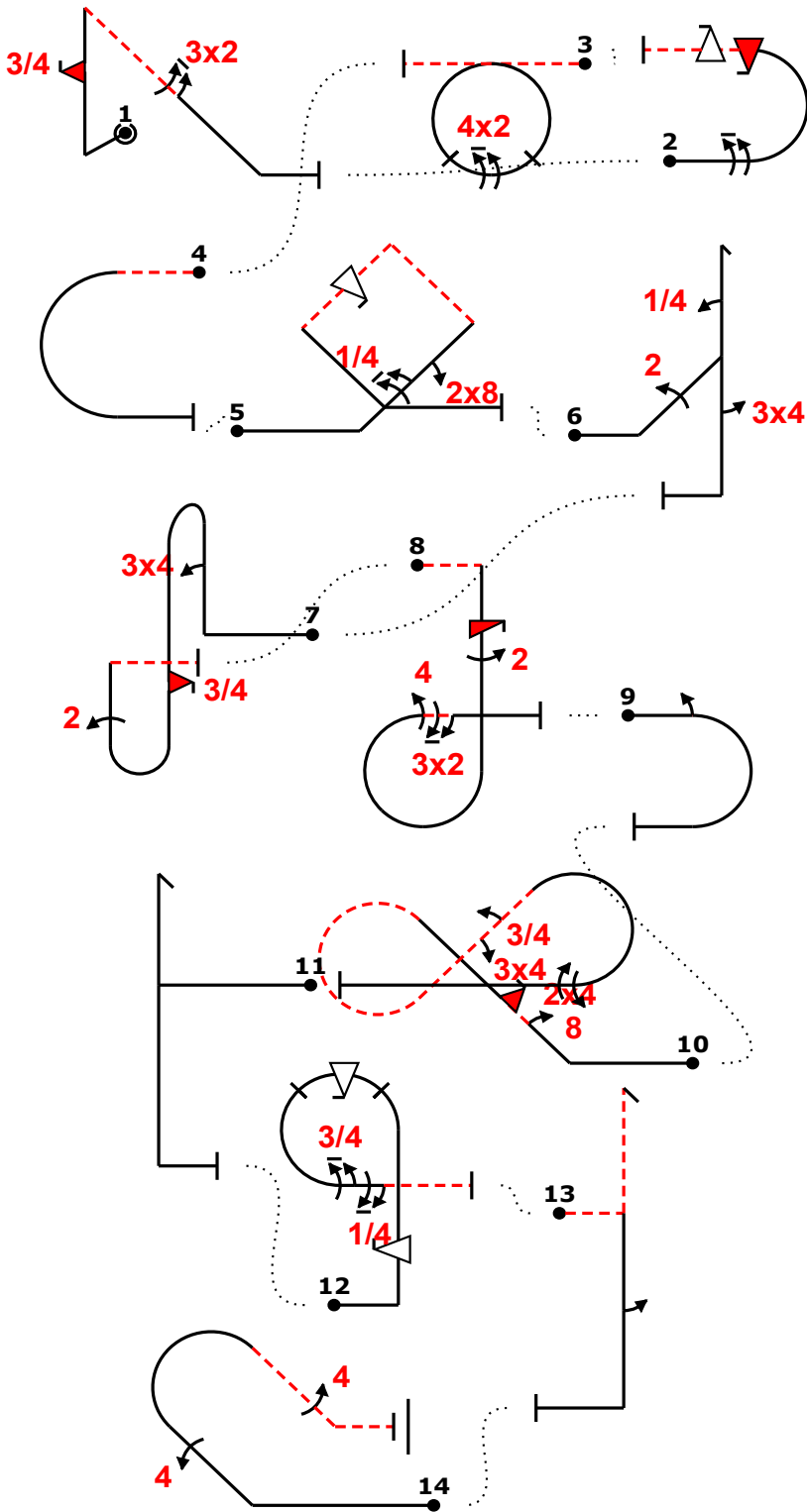
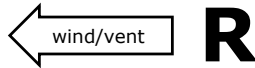

Fig	Grade	Pos	Remarks
1	.		
2	.		
3	.		
4	.		
5	.		
6	.		
7	.		
8	.		
9	.		
10	.		
11	.		
12	.		
13	.		
14	.		

Positioning
40 .

Too Low		Trg Violation	
Too High		Wing Rocks	
Interruptions		Disqual Fig	
Insertions		Other(note...)	

ej "0F" 3ifk32 (20,-1) "0B" 9mif,- (0,1) "0C" -io42- (-10,15) "0L" 3# -a (-1,1) "0A" 5,8dqf (1,2) "0I" 22dh(4)34." (-20,10) "0G" -34"bb(3if)22- (11,-7) "0J" -is;22irp44,32 (2,0) "0E" 2a (8,17) "0E" ,24;2ifrc(. ,34" ,["3" 88,1+ "0L" ++h.." (4,10) "0D" frp(f)7,5- (2,2) "0L" -'h.2.'-- (-3,7) "0H" 44db44-

Fig 1 F	K	Fig 2 B	K	Fig 3 C	K	Fig 4 L	K	Fig 5 A	K	Fig 6 I	K	Fig 7 G	K	Fig 8 J	K	Fig 9 L	K	Fig 10 E	K	Fig 11 L	K	Fig 12 D	K	Fig 13 L	K	Fig 14 H	K
1.2.7.1	13	7.2.1.1	6	7.4.1.4	11	7.2.1.4	6	7.4.5.1	15	5.3.1.1	18	8.8.1.1	18	8.6.2.4	12	7.2.3.3	6	7.8.5.1	20	5.2.1.1	17	8.6.2.1	12	5.2.1.4	22	8.4.13.1	11
9.10.6.3	19	9.1.3.8	12	9.2.3.8	15			9.1.2.5	11	9.2.2.4	11	9.4.1.3	12	9.12.1.4	7	9.1.3.2	4	9.4.2.2	7			9.9.1.4	15	9.1.5.2	4	9.4.2.4	13
9.2.4.6	12	9.10.8.4	15					9.8.2.1	5	9.1.1.1	6	9.10.10.3	15	9.2.5.4	9			9.10.2.2	15			9.9.3.4	11			9.4.4.4	11
		9.9.8.4	13					9.9.9.4	13	9.4.5.3	8	9.2.1.4	13	9.4.3.4	11			9.4.2.3	10			9.1.3.7	11				
														9.2.3.6	12			9.1.2.3	8			9.1.3.5	9				
																		9.8.3.4	15								
																		9.1.3.4	8								
	44		46		26		6		44		43		58		51		6		83		6		58		6		35



CIVA Unlimited

Programme3

Figure K

512

Total K

552

Judges Name		Flight #
Signature	Number	

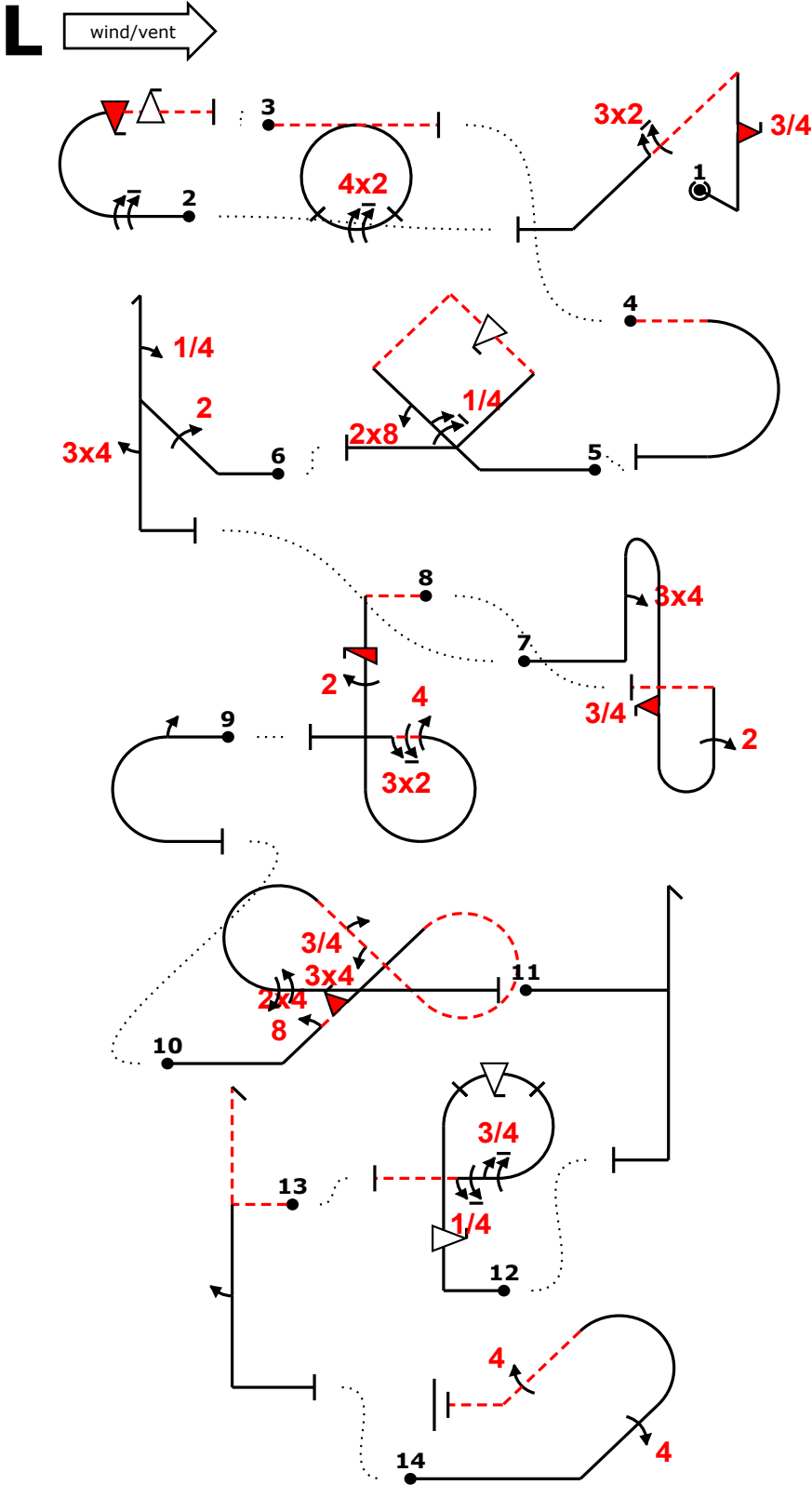

Fig	Grade	Pos	Remarks
1	.		
2	.		
3	.		
4	.		
5	.		
6	.		
7	.		
8	.		
9	.		
10	.		
11	.		
12	.		
13	.		
14	.		

Positioning
40 .

Too Low		Trg Violation	
Too High		Wing Rocks	
Interruptions		Disqual Fig	
Insertions		Other(note...)	

ej "0F" 3ifk32 (20,-1) "0B" 9mif,f- (0,1) "0C" -io42- (-10,15) "0L" 3% -a (-1,1) "0A" 5,8dqf (1,2) "0I" 22dh(4)34. (-20,10) "0G" -34"bb(3if)22- (11,-7) "0J" -is;22irp44,32 (2,0) "0E" 2a (8,17) "0E" ",24;2ifrc(.',34""|"3""88,1+" "0L" ++h..' (4,10) "0D" frp(f)7,5- (2,2) "0L" -'h.2.'-- (-3,7) "0H" 44db44-

Fig 1 F	K	Fig 2 B	K	Fig 3 C	K	Fig 4 L	K	Fig 5 A	K	Fig 6 I	K	Fig 7 G	K	Fig 8 J	K	Fig 9 L	K	Fig 10 E	K	Fig 11 L	K	Fig 12 D	K	Fig 13 L	K	Fig 14 H	K
1.2.7.1	13	7.2.1.1	6	7.4.1.4	11	7.2.1.4	6	7.4.5.1	15	5.3.1.1	18	8.8.1.1	18	8.6.2.4	12	7.2.3.3	6	7.8.5.1	20	5.2.1.1	17	8.6.2.1	12	5.2.1.4	22	8.4.13.1	11
9.10.6.3	19	9.1.3.8	12	9.2.3.8	15			9.1.2.5	11	9.2.2.4	11	9.4.1.3	12	9.12.1.4	7	9.1.3.2	4	9.4.2.2	7			9.9.1.4	15	9.1.5.2	4	9.4.2.4	13
9.2.4.6	12	9.10.8.4	15					9.8.2.1	5	9.1.1.1	6	9.10.10.3	15	9.2.5.4	9			9.10.2.2	15			9.9.3.4	11			9.4.4.4	11
		9.9.8.4	13					9.9.9.4	13	9.4.5.3	8	9.2.1.4	13	9.4.3.4	11			9.4.2.3	10			9.1.3.7	11				
														9.2.3.6	12			9.1.2.3	8			9.1.3.5	9				
																		9.8.3.4	15								
																		9.1.3.4	8								
	44		46		26		6		44		43		58		51		6		83		6		58		6	35	

Pilot: Proq E A/C:

wind/vent

