



CIVA		Form A
Pilot ID	<b>CIVA Unlimited Programme2</b>	Flight #

No	Symbol	Cat. No.	K	Total K	Grade	Pos	Remarks	Item	K	Grade
1		6.2.1.1 9.9.1.4 9.1.5.2	15 15 4	Fig C <b>34</b>	.			Pos.	40	
2		8.8.1.1 9.4.1.3 9.1.5.3 9.2.1.4	18 12 6 13	Fig J <b>49</b>	.			Harm.	0	
3		8.6.1.4 9.12.1.5 9.4.5.3 9.9.3.4 9.9.8.4	12 6 8 11 13	Fig A <b>50</b>	.			Fig K	492	Total K 532
4		7.2.1.4 9.1.3.5 9.1.3.1 9.1.3.6 9.4.3.2	6 9 2 10 5	Fig H <b>32</b>	.			<b>Penalties</b>		
5		7.8.3.1 9.1.3.8 9.2.4.6 9.2.4.4	19 12 12 9	Fig G <b>52</b>	.			Too Low		
6		8.4.4.2 9.1.1.1 9.1.5.1	14 6 2	additional Fig I <b>12</b>	.			Too High		
7		5.3.2.1 9.4.2.2 9.4.1.2 9.2.5.4	24 7 9 9	Fig I <b>49</b>	.			Interruptions		
8		5.2.1.1 9.10.6.4 9.10.5.2	17 19 13	Fig E <b>49</b>	.			Insertions		
9		8.4.1.1 9.1.1.5 9.10.10.3	13 14 15	Fig F <b>42</b>	.			Trg Violation		
10		8.6.4.1 9.9.1.2 9.2.3.8 9.1.3.4 9.2.3.6	14 15 15 8 12	Fig D <b>64</b>	.			Wing Rocks		
11		1.2.7.1 9.1.4.2	13 4	additional Fig B <b>12</b>	.			Disqual Fig		
12		8.5.6.1 9.4.3.4 9.2.3.4 9.10.4.4 9.1.4.2	10 11 9 13 4	Fig B <b>47</b>	.			Other(note...)		
								<b>Final Freestyle</b>		
								Duration	Min	Sec
								<b>Judges Details</b>		
								Signature		
								Name		
								Number		

Prog F ..... Pilot  
 ..... A/C



		Form B
Pilot ID	CIVA Unlimited Programme2	
	Flight #	

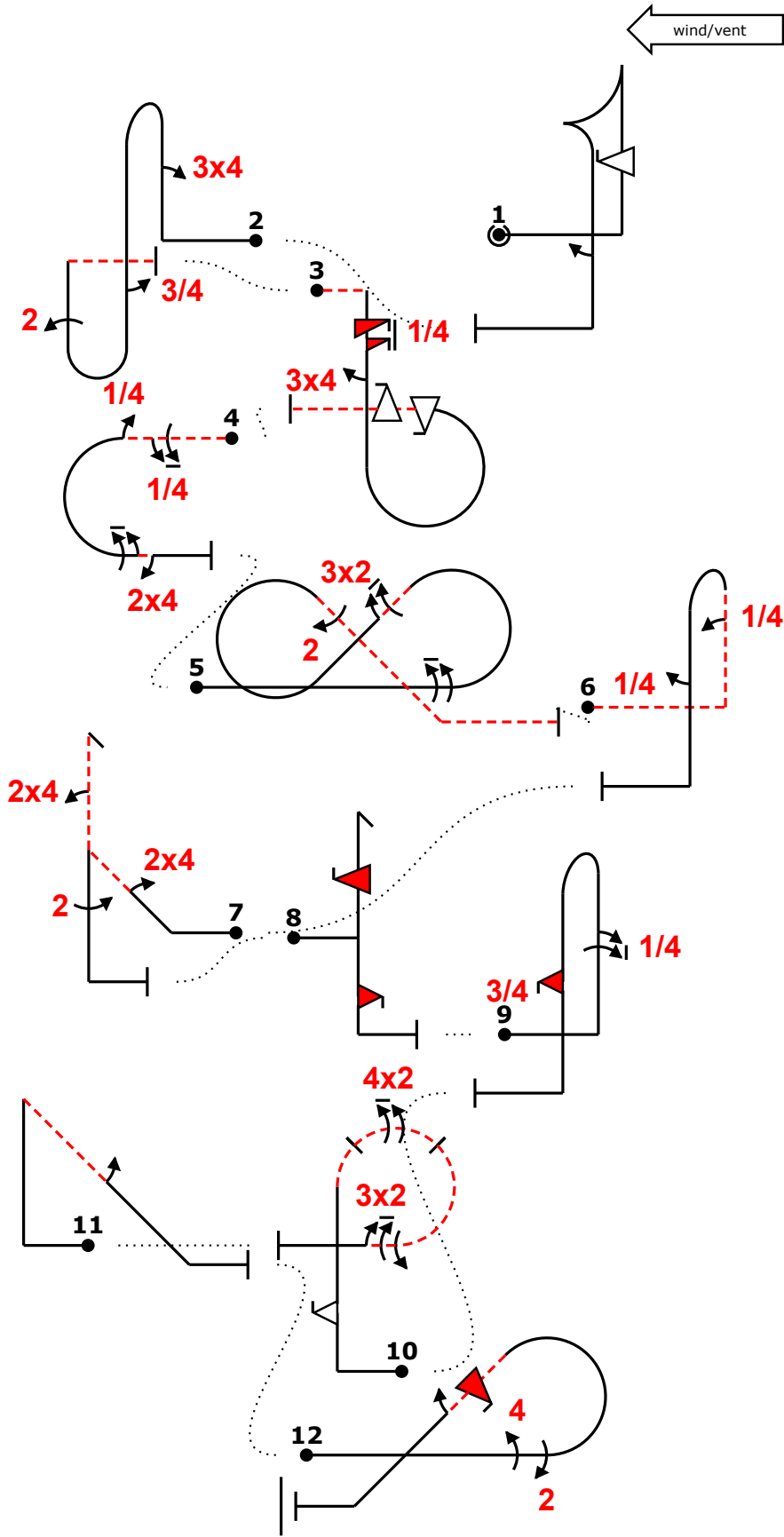

"@C" .fta^,2. (-11,-6) "@J" ,34''bb(3)22- (7,2) "@A" ^-5is,34irpf,f- (0,2) "@H" -5,4a6,24 (-5,9) "@G" 9cc(,32),22- (-2,-1) "@L" --"|"4b^,4. (-21,10) "@I" ,24dh(24)"|22. (6,-3) "@E" ifh2if (2,0) "@F" ,5'b,3if. (-1,19) "@D" 2frp(42)1,32 (-9,0) "@L" k2 (0,13) "@B" 44,22cif,2

Prog F  
Pilot  
A/C



		Form C
Pilot ID	CIVA Unlimited Programme2	
	Flight #	

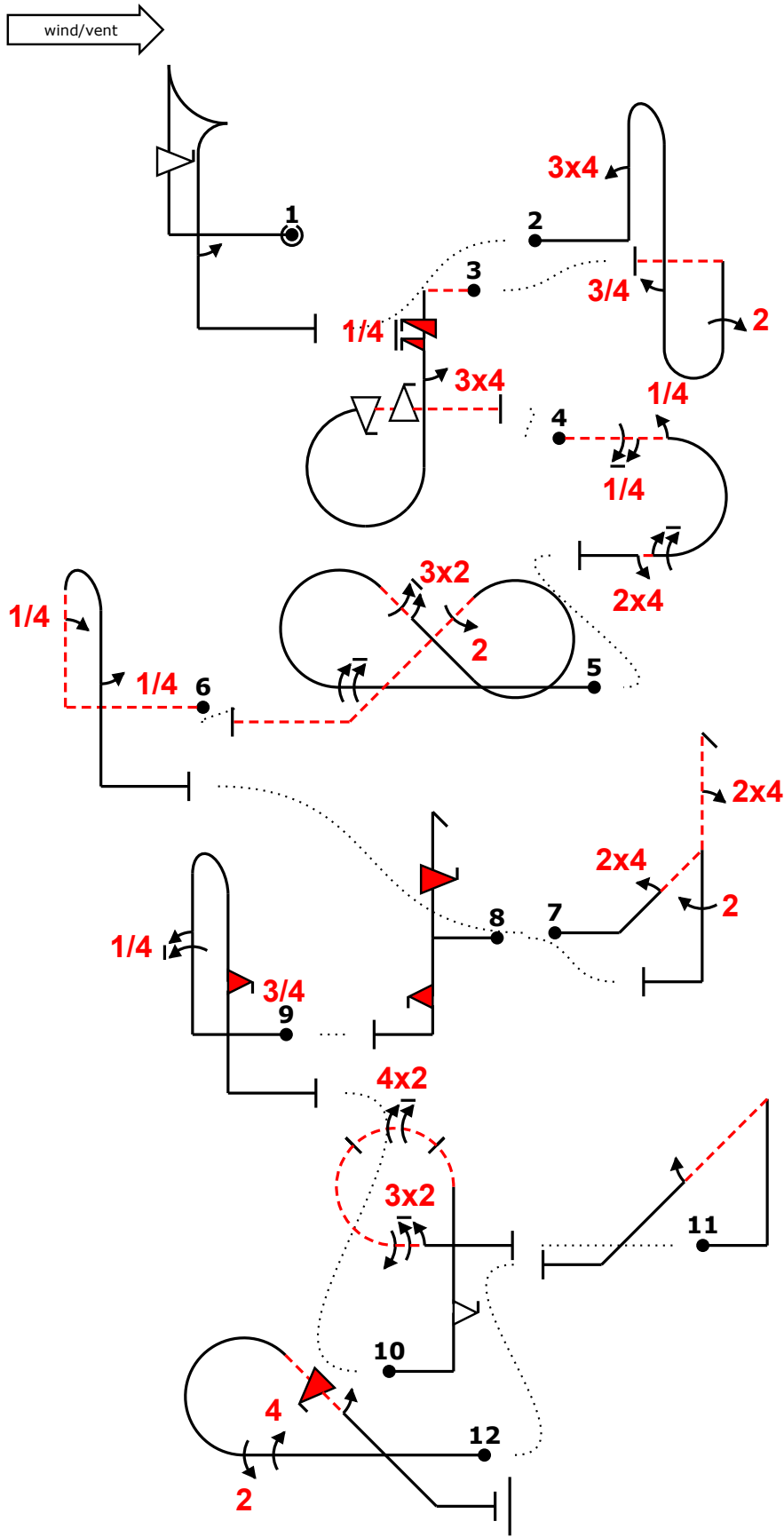

"@C" .fta^,2. (-11,-6) "@J" ,34''bb(3)22- (7,2) "@A" ^-5is,34irpf,f- (0,2) "@H" -5,4a6,24 (-5,9) "@G" 9cc(,32),22- (-2,-1) "@L" --"|"4b^,4. (-21,10) "@I" ,24dh(24)"|"22. (6,-3) "@E" ifh2if (2,0) "@F" ,5'b,3if. (-1,19) "@D" 2frp(42)1,32 (-9,0) "@L" k2 (0,13) "@B" 44,22cif,2

Prog F ..... Pilot  
 ..... A/C



Judges Name		Flight #
Signature	Number	

wind/vent **R**

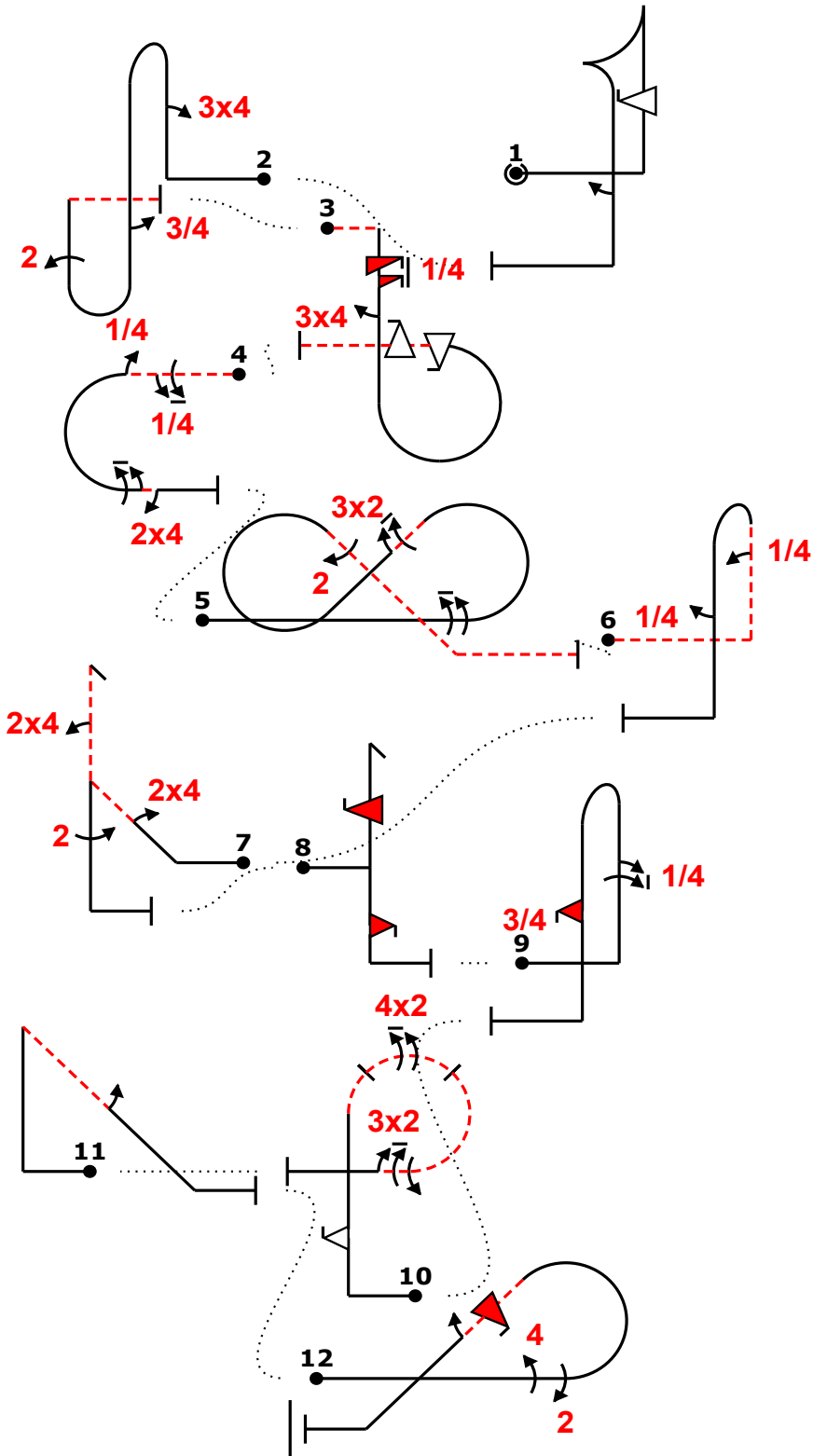

Fig	Grade	Pos	Remarks
1	.		
2	.		
3	.		
4	.		
5	.		
6	.		
7	.		
8	.		
9	.		
10	.		
11	.		
12	.		

Positioning  
**40** .

Too Low		Trg Violation	
Too High		Wing Rocks	
Interruptions		Disqual Fig	
Insertions		Other(note...)	

"@C".fta",2. (-11,-6) "@J",34''bb(3)22- (7,2) "@A" ~-5is,34irpf,f- (0,2) "@H" -5,4a6,24 (-5,9) "@G" 9cc(,32),22- (-2,-1) "@L" --|"4b",4. (-21,10) "@I",24dh(24)|"22. (6,-3) "@E" ifh2if (2,0) "@F",5''b,3if. (-1,19) "@D" 2frp(42)1,32 (-9,0) "@L" k2 (0,13) "@B" 44,22cif,2

Fig 1 C	K	Fig 2 J	K	Fig 3 A	K	Fig 4 H	K	Fig 5 G	K	Fig 6 L	K	Fig 7 I	K	Fig 8 E	K	Fig 9 F	K	Fig 10 D	K	Fig 11 L	K	Fig 12 B	K
6.2.1.1	15	8.8.1.1	18	8.6.1.4	12	7.2.1.4	6	7.8.3.1	19	8.4.4.2	14	5.3.2.1	24	5.2.1.1	17	8.4.1.1	13	8.6.4.1	14	1.2.7.1	13	8.5.6.1	10
9.9.1.4	15	9.4.1.3	12	9.12.1.5	6	9.1.3.5	9	9.1.3.8	12	9.1.1.1	6	9.4.2.2	7	9.10.6.4	19	9.1.1.5	14	9.9.1.2	15	9.1.4.2	4	9.4.3.4	11
9.1.5.2	4	9.1.5.3	6	9.4.5.3	8	9.1.3.1	2	9.2.4.6	12	9.1.5.1	2	9.4.1.2	9	9.10.5.2	13	9.10.10.3	15	9.2.3.8	15			9.2.3.4	9
		9.2.1.4	13	9.9.3.4	11	9.1.3.6	10	9.2.4.4	9			9.2.5.4	9					9.1.3.4	8			9.10.4.4	13
				9.9.8.4	13	9.4.3.2	5											9.2.3.6	12			9.1.4.2	4
	<b>34</b>		<b>49</b>		<b>50</b>		<b>32</b>		<b>52</b>		<b>12</b>		<b>49</b>		<b>49</b>		<b>42</b>		<b>64</b>		<b>12</b>		<b>47</b>

Pilot: Proq F

A/C:



Judges Name		Flight #
Signature	Number	

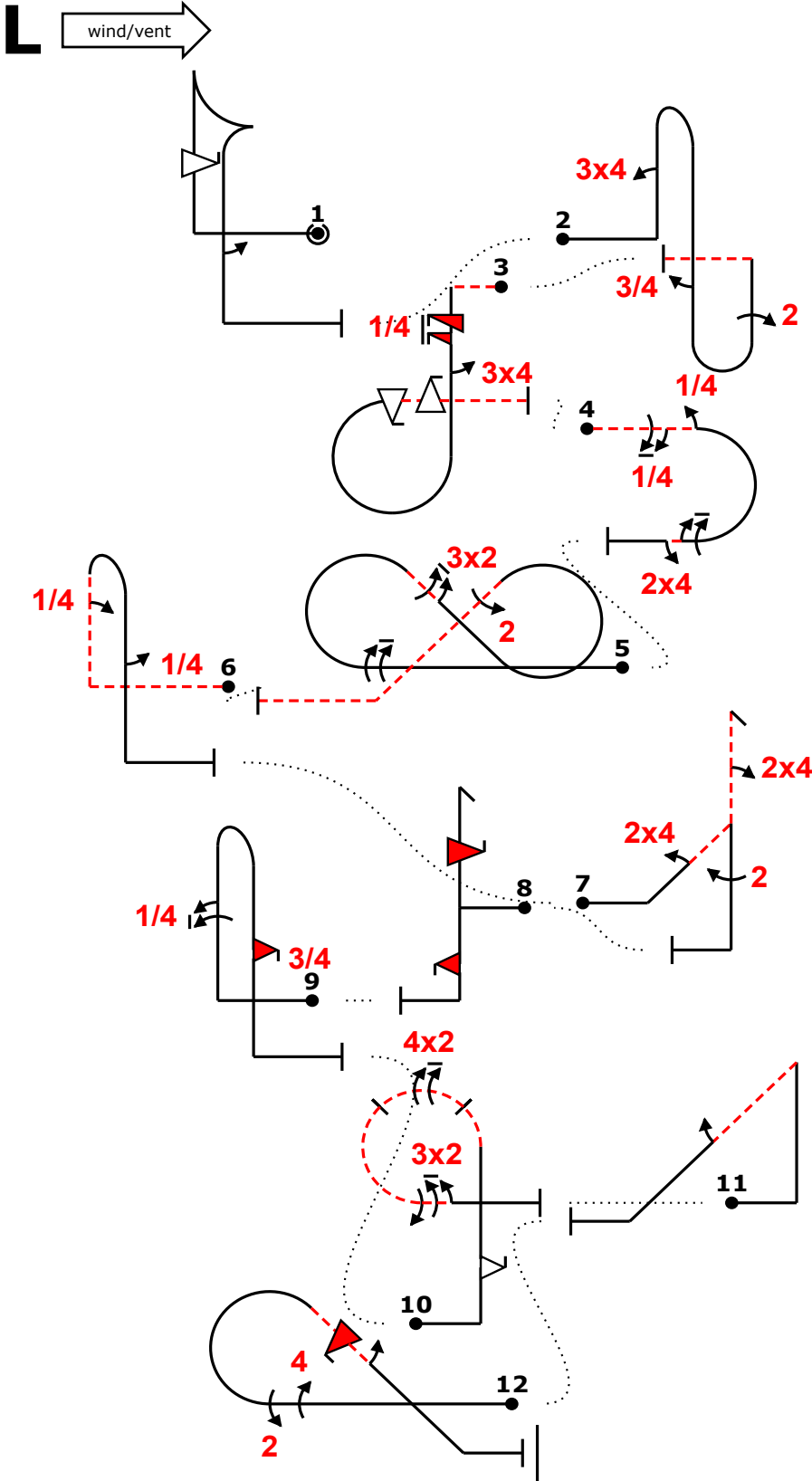

Fig	Grade	Pos	Remarks
1	.		
2	.		
3	.		
4	.		
5	.		
6	.		
7	.		
8	.		
9	.		
10	.		
11	.		
12	.		

Positioning  
40 .

Too Low		Trg Violation	
Too High		Wing Rocks	
Interruptions		Disqual Fig	
Insertions		Other(note...)	

"@C".fta",2. (-11,-6) "@J",34''bb(3)22- (7,2) "@A" ~-5is,34irpf,f- (0,2) "@H" -5,4a6,24 (-5,9) "@G" 9cc,(32),22- (-2,-1) "@L" --|"4b",4. (-21,10) "@I",24dh(24)|"22. (6,-3) "@E" ifh2if (2,0) "@F",5''b,3if. (-1,19) "@D" 2frp(42)1,32 (-9,0) "@L" k2 (0,13) "@B" 44,22cif,2

Fig 1 C	K	Fig 2 J	K	Fig 3 A	K	Fig 4 H	K	Fig 5 G	K	Fig 6 L	K	Fig 7 I	K	Fig 8 E	K	Fig 9 F	K	Fig 10 D	K	Fig 11 L	K	Fig 12 B	K
6.2.1.1	15	8.8.1.1	18	8.6.1.4	12	7.2.1.4	6	7.8.3.1	19	8.4.4.2	14	5.3.2.1	24	5.2.1.1	17	8.4.1.1	13	8.6.4.1	14	1.2.7.1	13	8.5.6.1	10
9.9.1.4	15	9.4.1.3	12	9.12.1.5	6	9.1.3.5	9	9.1.3.8	12	9.1.1.1	6	9.4.2.2	7	9.10.6.4	19	9.1.1.5	14	9.9.1.2	15	9.1.4.2	4	9.4.3.4	11
9.1.5.2	4	9.1.5.3	6	9.4.5.3	8	9.1.3.1	2	9.2.4.6	12	9.1.5.1	2	9.4.1.2	9	9.10.5.2	13	9.10.10.3	15	9.2.3.8	15			9.2.3.4	9
		9.2.1.4	13	9.9.3.4	11	9.1.3.6	10	9.2.4.4	9			9.2.5.4	9					9.1.3.4	8			9.10.4.4	13
				9.9.8.4	13	9.4.3.2	5											9.2.3.6	12			9.1.4.2	4
	34		49		50		32		52		12		49		49		42		64		12		47

Pilot: Proq F

A/C:

