



	Form A
Pilot ID	Flight #
CIVA Unlimited Programme2	

No	Symbol	Cat. No.	K	Total K	Grade	Pos	Remarks	Item	K	Grade	
1		8.6.1.4 9.12.1.5 9.4.5.3 9.9.3.4 9.9.8.4	12 6 8 11 13	Fig A 50	.			Pos.	40		
2		5.2.1.4 9.1.5.2	22 4	additional 6	.			Harm.	0		
3		8.5.6.1 9.4.3.4 9.2.3.4 9.10.4.4 9.1.4.2	10 11 9 13 4	Fig B 47	.			Fig K	492	Total K 532	
4		8.4.1.1 9.1.1.5 9.10.10.3	13 14 15	Fig F 42	.			Penalties			
5		8.8.1.1 9.4.1.3 9.1.5.3 9.2.1.4	18 12 6 13	Fig J 49	.			Too Low			
6		7.2.1.4 9.1.3.5 9.1.3.1 9.1.3.6 9.4.3.2	6 9 2 10 5	Fig H 32	.			Too High			
7		6.2.1.1 9.9.1.4 9.1.5.2	15 15 4	Fig C 34	.			Interruptions			
8		8.6.4.1 9.9.1.2 9.2.3.8 9.1.3.4 9.2.3.6	14 15 15 8 12	Fig D 64	.			Insertions			
9		5.2.1.1	17	additional 6	.			Trg Violation			
10		5.2.1.1 9.10.6.4 9.10.5.2	17 19 13	Fig E 49	.			Wing Rocks			
11		5.2.1.1	17	additional 6	.			Disqual Fig			
12		7.8.3.1 9.1.3.8 9.2.4.6 9.2.4.4	19 12 12 9	Fig G 52	.			Other(note...)			
13		5.2.1.4 9.1.5.2	22 4	additional 6	.			Final Freestyle			
14		5.3.2.1 9.4.2.2 9.4.1.2 9.2.5.4	24 7 9 9	Fig I 49	.			Duration	Min	Sec	
									Judges Details		
									Signature		
									Name		
									Number		

Prog A Pilot
 A/C



		Form B
Pilot ID	CIVA Unlimited Programme2	
	Flight #	

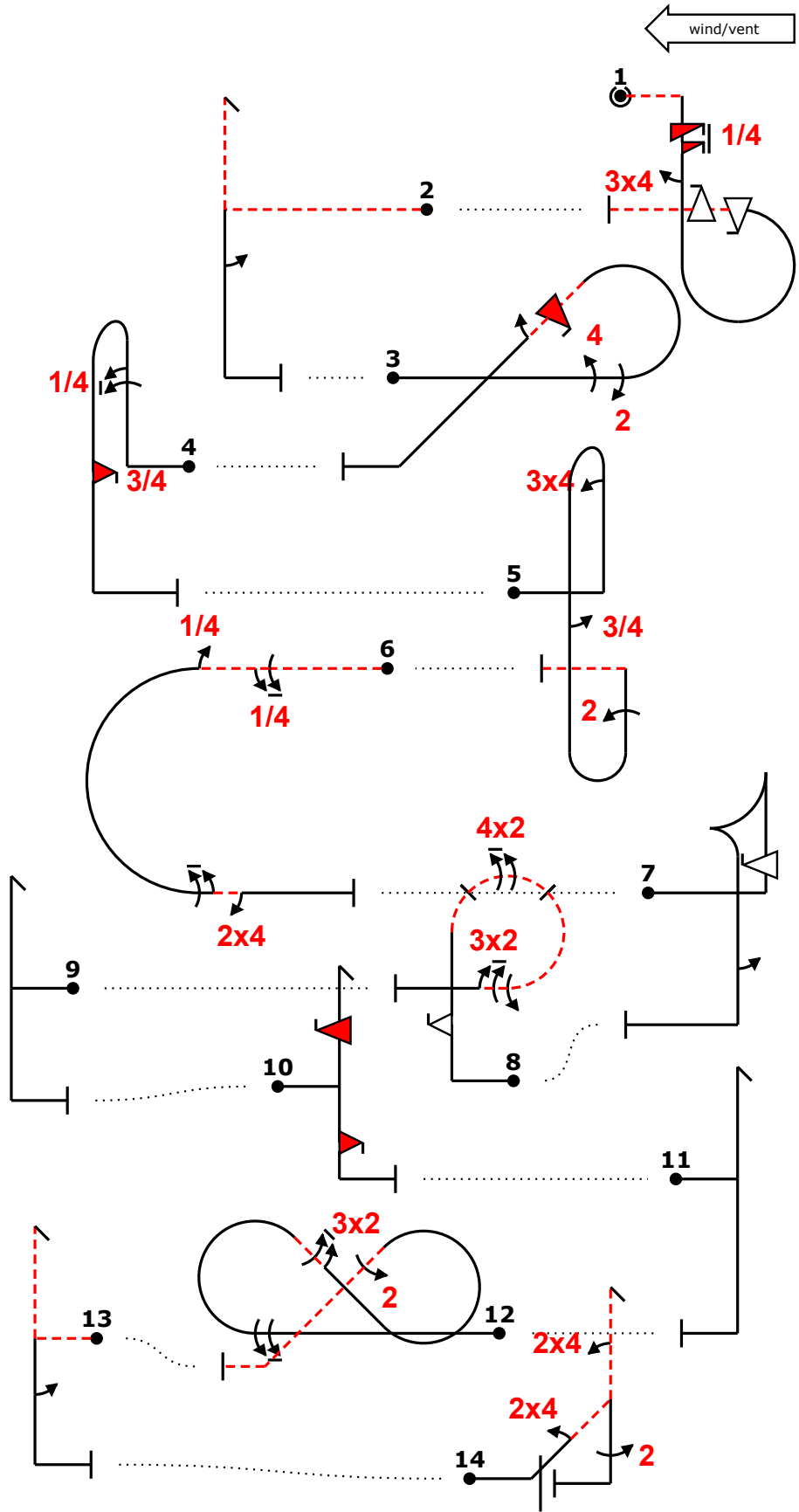

"0A" -5is,34irpf,f- (-9,0) "0L" -----h2.. (4,0) "0B" 44,22cif,2.' (-7,0) "0F" ``+5b''3if.' (20,0) "0J" .34bb(3.'')'22`- (-7,0) "0H" 10% -5,4a6,24 (17,0) "0C" fta2'' (-4,4) "0D" 2F`rp(42)1,32 (-19,0) "0L" h'' (11,-1) "0E" ifh2if (16,0) "0L" h.' (-9,0) "0G" 9cc(32)22----- (-5,-2) "0L" -h2. (23,1) "0I" 24dh(24)22

Prog A Pilot
 A/C



		Form C
Pilot ID	CIVA Unlimited Programme2	
	Flight #	

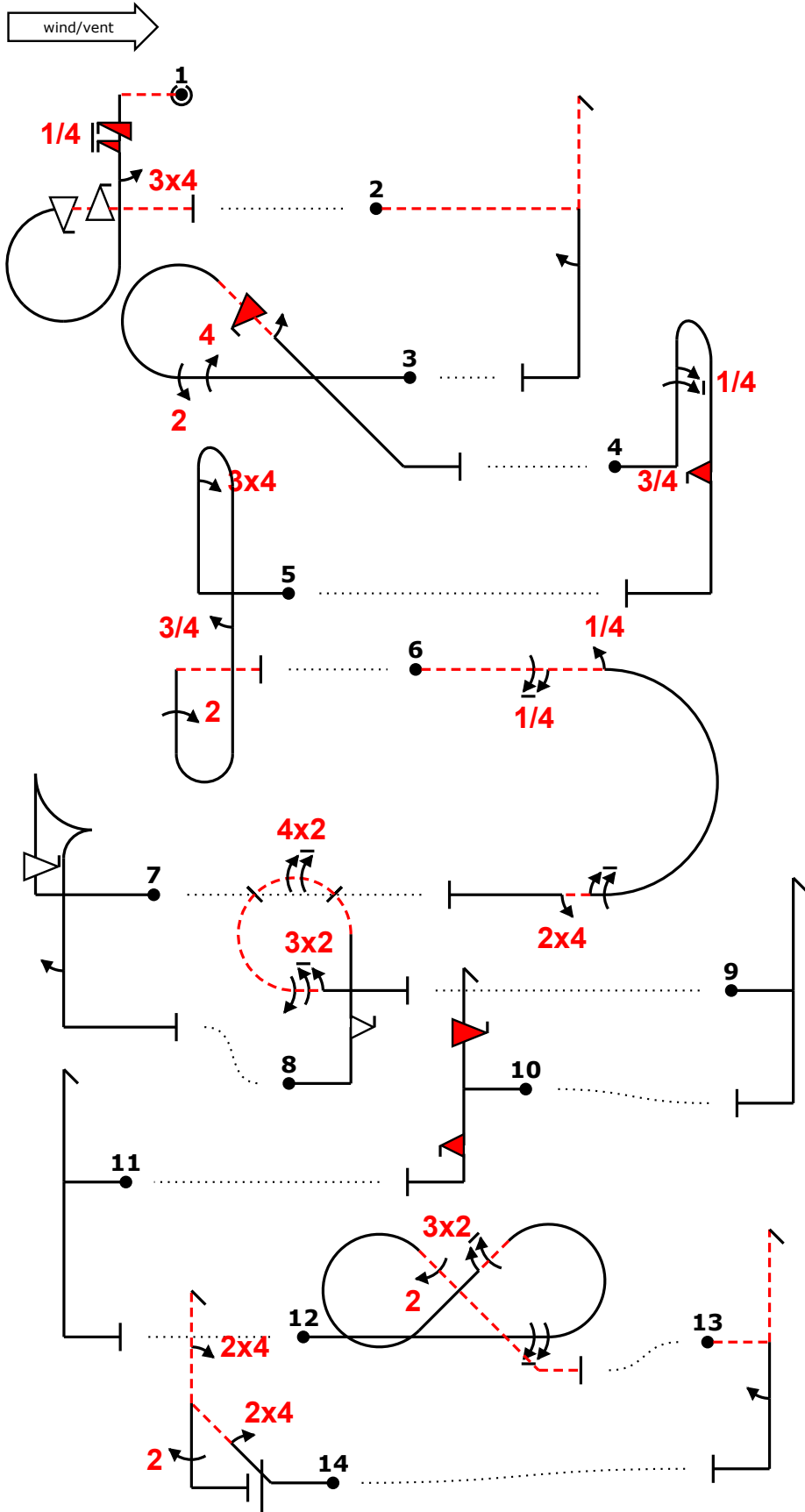

"0A" -5is,34irpf,f- (-9,0) "0L" ----h2.. (4,0) "0B" 44,22cif,2.' (-7,0) "0F" ``+5b''3if.' (20,0) "0J" .34bb(3.'')'22`- (-7,0) "0H" 10% -5,4a6,24 (17,0) "0C" fta2'' (-4,4) "0D" 2F`rp(42)1,32 (-19,0) "0L" h'' (11,-1) "0E" ifh2if (16,0) "0L" h.' (-9,0) "0G" 9cc(32)22-~~~~ (-5,-2) "0L" -h2. (23,1) "0I" 24dh(24)22

Prog A
Pilot
A/C

wind/vent ← **R**

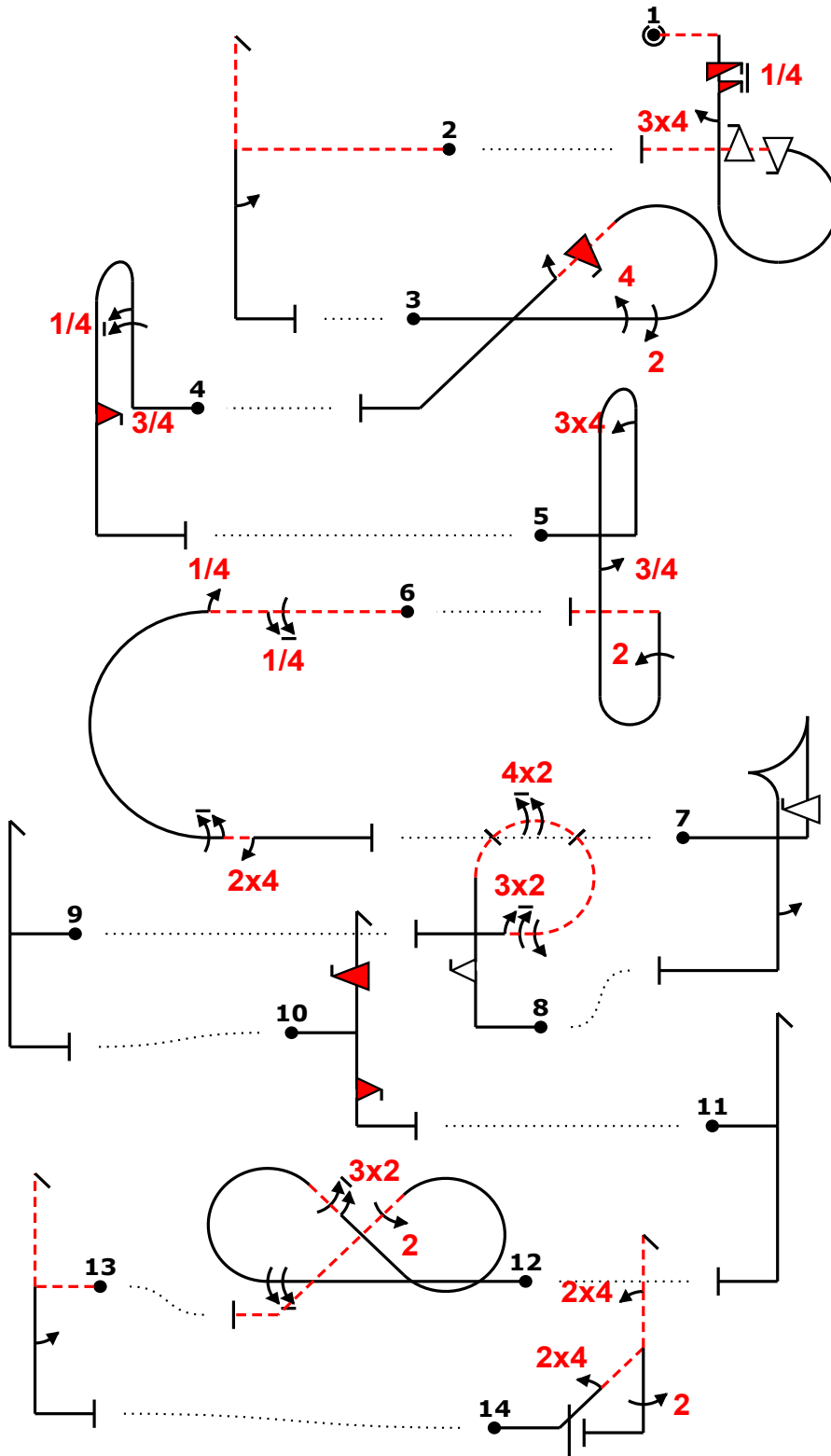

Fig	Grade	Pos	Remarks
1	.		
2	.		
3	.		
4	.		
5	.		
6	.		
7	.		
8	.		
9	.		
10	.		
11	.		
12	.		
13	.		
14	.		

Positioning
40

Too Low		Trg Violation	
Too High		Wing Rocks	
Interruptions		Disqual Fig	
Insertions		Other(note...)	

"0A" -5is,34irpf,f- (-9,0) "0L" -----h2.. (4,0) "0B" 44,22cif,2.' (-7,0) "0P" ~~~+5b'13if.' (20,0) "0J" ..34bb(3.'')'22' - (-7,0) "0H" 10% -5,4a6,24 (17,0) "0C" fta2'1' (-4,4) "0D" 2f`rp(42)1,32 (-19,0) "0L" h'' (11,-1) "0E" ifh2if (16,0) "0L" h.' (-9,0) "0G" 9cc(32)22-~~~~ (-5,-2) "0L" -h2. (23,1) "0I" 24dh(24)22

Fig 1 A	K	Fig 2 L	K	Fig 3 B	K	Fig 4 F	K	Fig 5 J	K	Fig 6 H	K	Fig 7 C	K	Fig 8 D	K	Fig 9 L	K	Fig 10 E	K	Fig 11 L	K	Fig 12 G	K	Fig 13 L	K	Fig 14 I	K
8.6.1.4	12	5.2.1.4	22	8.5.6.1	10	8.4.1.1	13	8.8.1.1	18	7.2.1.4	6	6.2.1.1	15	8.6.4.1	14	5.2.1.1	17	5.2.1.1	17	5.2.1.1	17	7.8.3.1	19	5.2.1.4	22	5.3.2.1	24
9.12.1.5	6	9.1.5.2	4	9.4.3.4	11	9.1.1.5	14	9.4.1.3	12	9.1.3.5	9	9.9.1.4	15	9.9.1.2	15			9.10.6.4	19			9.1.3.8	12	9.1.5.2	4	9.4.2.2	7
9.4.5.3	8			9.2.3.4	9	9.10.10.3	15	9.1.5.3	6	9.1.3.1	2	9.1.5.2	4	9.2.3.8	15			9.10.5.2	13			9.2.4.6	12			9.4.1.2	9
9.9.3.4	11			9.10.4.4	13			9.2.1.4	13	9.1.3.6	10			9.1.3.4	8							9.2.4.4	9			9.2.5.4	9
9.9.8.4	13			9.1.4.2	4					9.4.3.2	5			9.2.3.6	12												
	50		6		47		42		49		32		34		64		6		49		6		52		6	49	

Pilot: Proq A

A/C:



Judges Name		Flight #
Signature	Number	

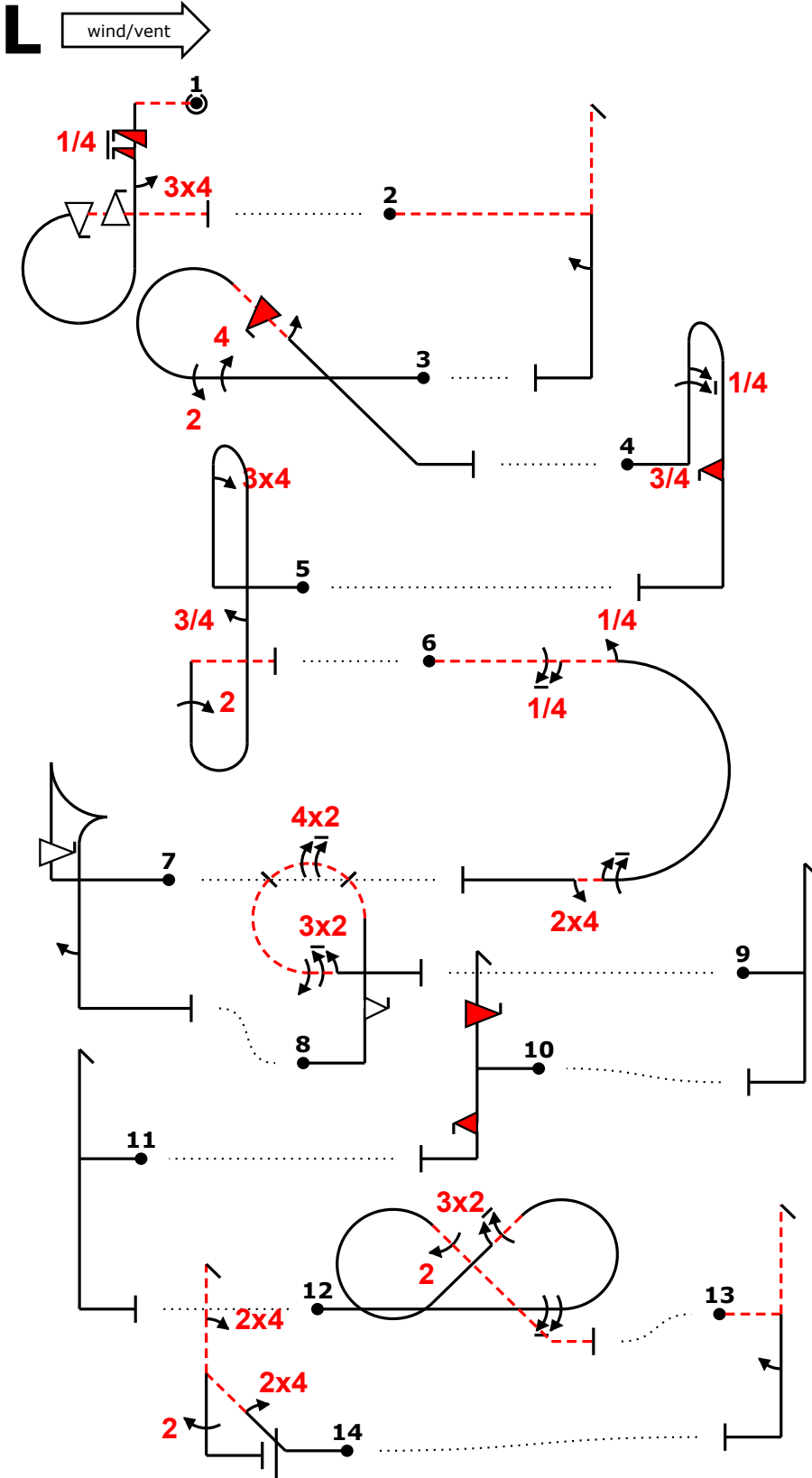

Fig	Grade	Pos	Remarks
1	.		
2	.		
3	.		
4	.		
5	.		
6	.		
7	.		
8	.		
9	.		
10	.		
11	.		
12	.		
13	.		
14	.		

Positioning
40 .

Too Low		Trg Violation	
Too High		Wing Rocks	
Interruptions		Disqual Fig	
Insertions		Other(note...)	

"@A" -5is,34irpf,f- (-9,0) "@L" -----h2.. (4,0) "@B" 44,22cif,2.' (-7,0) "@F" ~~~+5b''3if.' (20,0) "@J" ..34bb(3.'')'22"- (-7,0) "@H" 10% -5,4a6,24 (17,0) "@C" fta2'' (-4,4) "@D" 2f`rp(42)1,32 (-19,0) "@L" h'' (11,-1) "@E" ifh2if (16,0) "@L" h.' (-9,0) "@G" 9cc(32)22-~~~~ (-5,-2) "@L" -h2. (23,1) "@I" 24dh(24)22

Fig 1 A	K	Fig 2 L	K	Fig 3 B	K	Fig 4 F	K	Fig 5 J	K	Fig 6 H	K	Fig 7 C	K	Fig 8 D	K	Fig 9 L	K	Fig 10 E	K	Fig 11 L	K	Fig 12 G	K	Fig 13 L	K	Fig 14 I	K
8.6.1.4	12	5.2.1.4	22	8.5.6.1	10	8.4.1.1	13	8.8.1.1	18	7.2.1.4	6	6.2.1.1	15	8.6.4.1	14	5.2.1.1	17	5.2.1.1	17	5.2.1.1	17	7.8.3.1	19	5.2.1.4	22	5.3.2.1	24
9.12.1.5	6	9.1.5.2	4	9.4.3.4	11	9.1.1.5	14	9.4.1.3	12	9.1.3.5	9	9.9.1.4	15	9.9.1.2	15			9.10.6.4	19			9.1.3.8	12	9.1.5.2	4	9.4.2.2	7
9.4.5.3	8			9.2.3.4	9	9.10.10.3	15	9.1.5.3	6	9.1.3.1	2	9.1.5.2	4	9.2.3.8	15			9.10.5.2	13			9.2.4.6	12			9.4.1.2	9
9.9.3.4	11			9.10.4.4	13			9.2.1.4	13	9.1.3.6	10			9.1.3.4	8							9.2.4.4	9			9.2.5.4	9
9.9.8.4	13			9.1.4.2	4					9.4.3.2	5			9.2.3.6	12												
	50		6		47		42		49		32		34		64		6		49		6		52		6		49

Pilot: Proq A

A/C:

wind/vent ←

