



| | | |
|----------|---------------------------------|----------|
| CIVA | | Form A |
| Pilot ID | CIVA Advanced Programme3 | Flight # |

| No | Symbol | Cat. No. | K | Total K | Grade | Pos | Remarks | Item | K | Grade |
|----|--------|--|-------------------|------------------------|-------|-----|---------|------------------------|-----|----------------|
| 1 | | 7.2.4.3 9.1.3.4 9.9.3.6 9.4.3.2 | 6 8 14 5 | Fig A 33 | . | | | Pos. | 30 | |
| 2 | | 7.2.1.2 9.4.3.4 9.8.3.4 | 8 11 15 | Fig E 34 | . | | | Harm. | 0 | |
| 3 | | 1.1.1.3 9.1.3.2 | 2 4 | additional 6 | . | | | Fig K | 316 | Total K 346 |
| 4 | | 7.3.4.4 9.4.4.2 9.1.4.2 | 15 5 4 | Fig J 24 | . | | | Penalties | | |
| 5 | | 6.2.2.1 | 15 | Fig B 15 | . | | | Too Low | | |
| 6 | | 7.2.1.1 | 6 | additional 6 | . | | | Too High | | |
| 7 | | 8.6.1.4 9.12.1.4 9.2.3.4 | 12 7 9 | Fig F 28 | . | | | Interruptions | | |
| 8 | | 7.2.2.4 9.8.3.2 9.9.3.2 9.1.3.2 | 7 7 11 4 | Fig C 29 | . | | | Insertions | | |
| 9 | | 8.4.4.2 9.1.1.3 9.9.5.3 | 14 10 11 | Fig D 35 | . | | | Trg Violation | | |
| 10 | | 1.1.1.3 9.1.3.2 | 2 4 | additional 6 | . | | | Wing Rocks | | |
| 11 | | 8.5.1.2 9.2.2.4 9.1.3.8 | 10 11 12 | Fig G 33 | . | | | Disqual Fig | | |
| 12 | | 5.2.1.3 9.1.1.2 9.1.5.1 | 18 8 2 | Fig I 28 | . | | | Other(note...) | | |
| 13 | | 1.1.7.2 9.1.1.1 | 12 6 | additional 6 | . | | | Final Freestyle | | |
| 14 | | 1.2.3.3 9.9.4.2 9.8.1.1 | 15 11 7 | Fig H 33 | . | | | Duration | Min | Sec |
| | | | | | | | | Judges Details | | |
| | | | | | | | | Signature | | |
| | | | | | | | | Name | | |
| | | | | | | | | Number | | |

Prog B Pilot
 A/C



| | | |
|----------|--------------------------|----------|
| | | Form B |
| Pilot ID | CIVA Advanced Programme3 | Flight # |

wind/vent ←

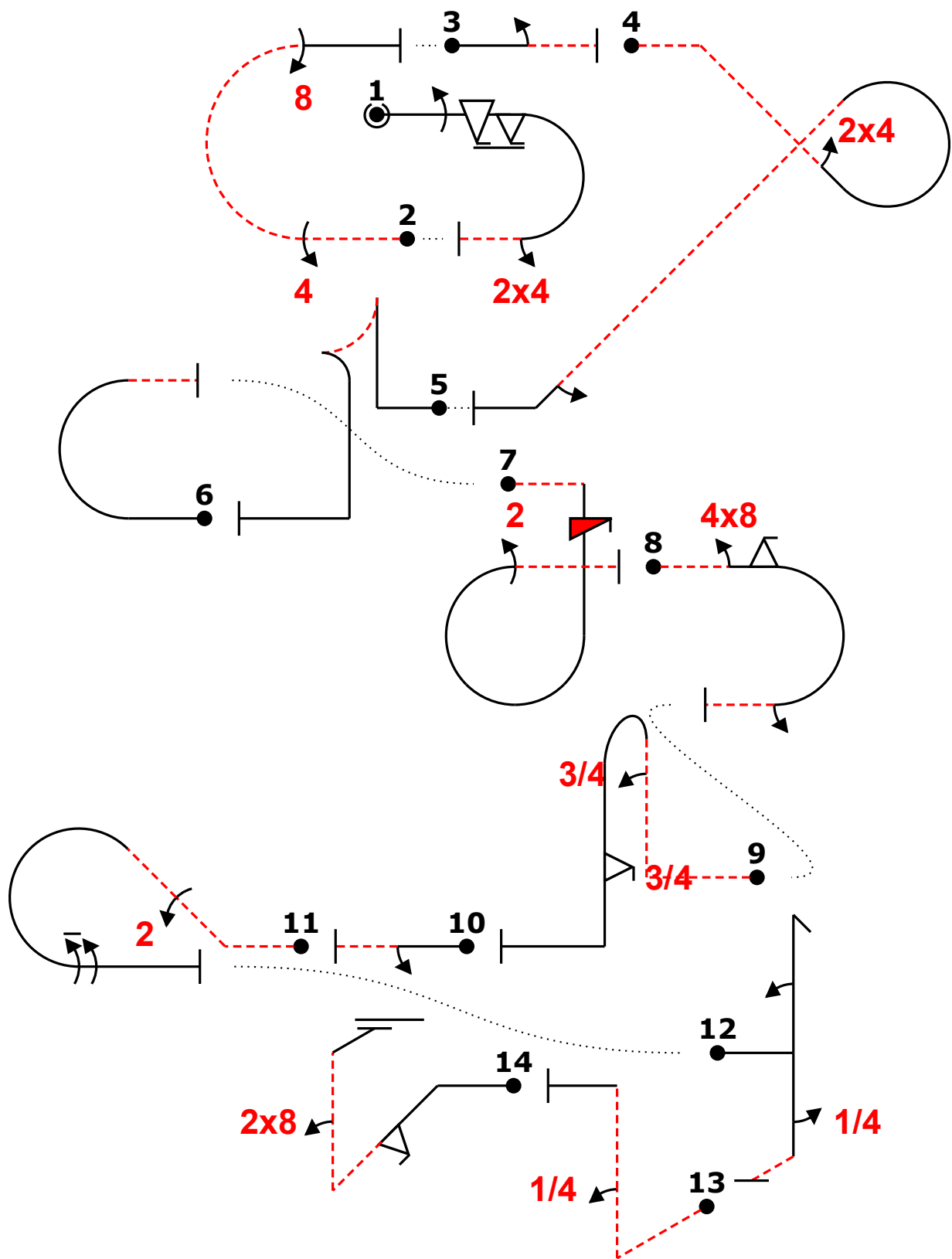

"@A" -1% 1,6fa24- (1,0) "@E" 4% -44m,88 (-1,0) "@L" 2- "@J" -1% -.24ig.....2 (2,0) "@B" -2% ~~~~+ita "@L" m- (14,6) "@F" -i sirp22- "@C" -48;2fa2- (7,10) "@D" -3b3f> "@L" -1% 2- "@G" -.....22rc9+..... (26,5) "@I" 2h4- "@L" > ---v4'' "@H" 2fit8^

Prog B Pilot
 A/C



| | | |
|----------|--------------------------|----------|
| | | Form C |
| Pilot ID | CIVA Advanced Programme3 | Flight # |

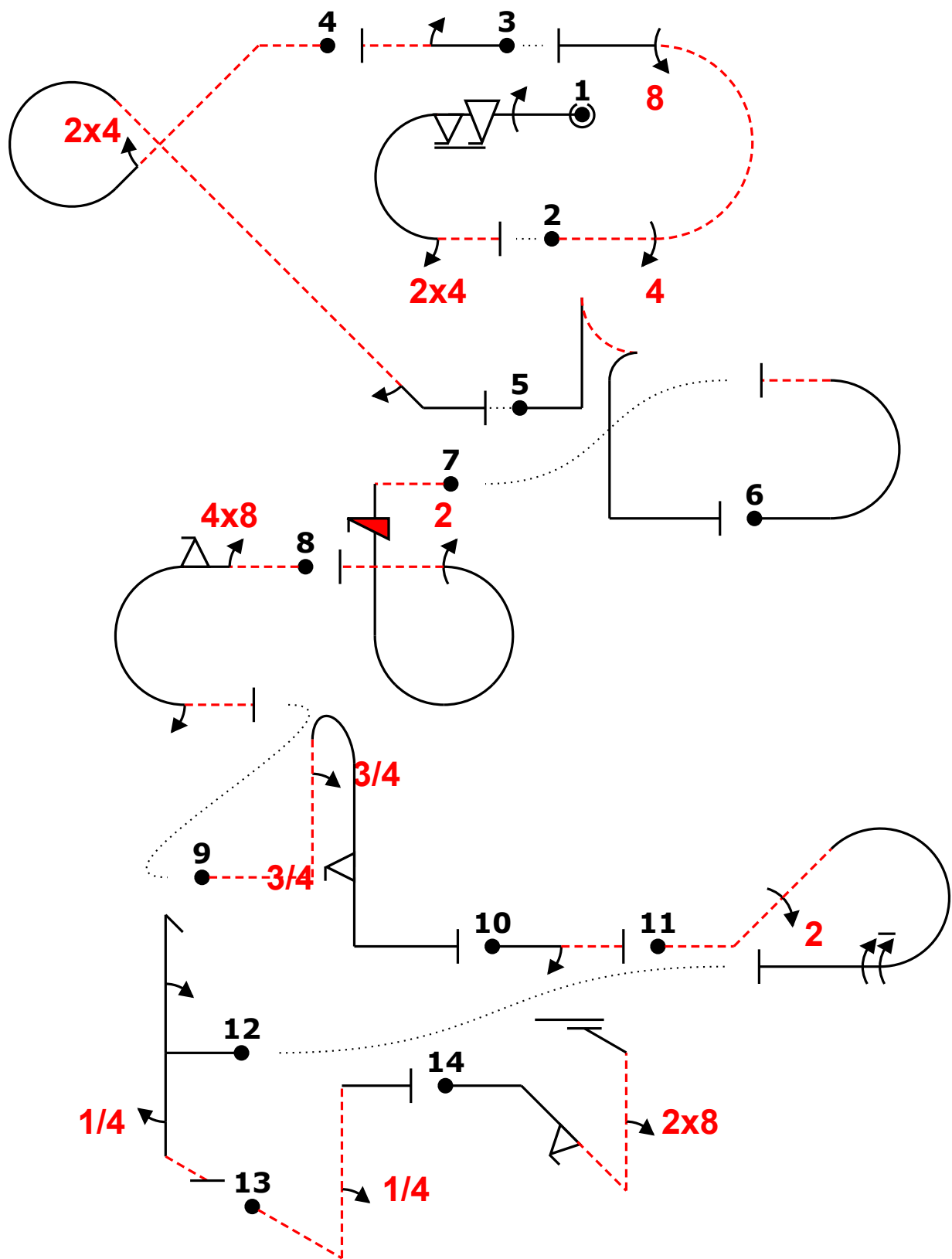
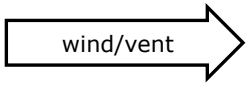

"@A" -1% 1,6fa24- (1,0) "@E" 4% -44m,88 (-1,0) "@L" 2- "@J" -1% -.24ig.....2 (2,0) "@B" -2% ~~~~~+ita "@L" m- (14,6) "@F" -i
 sirp22- "@C" -48;2fa2- (7,10) "@D" -3b3f> "@L" -1% 2- "@G" -.....22rc9+..... (26,5) "@I" 2h4- "@L" > ---v4'' "@H" 2fit8^

Prog B Pilot
 A/C

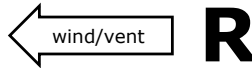
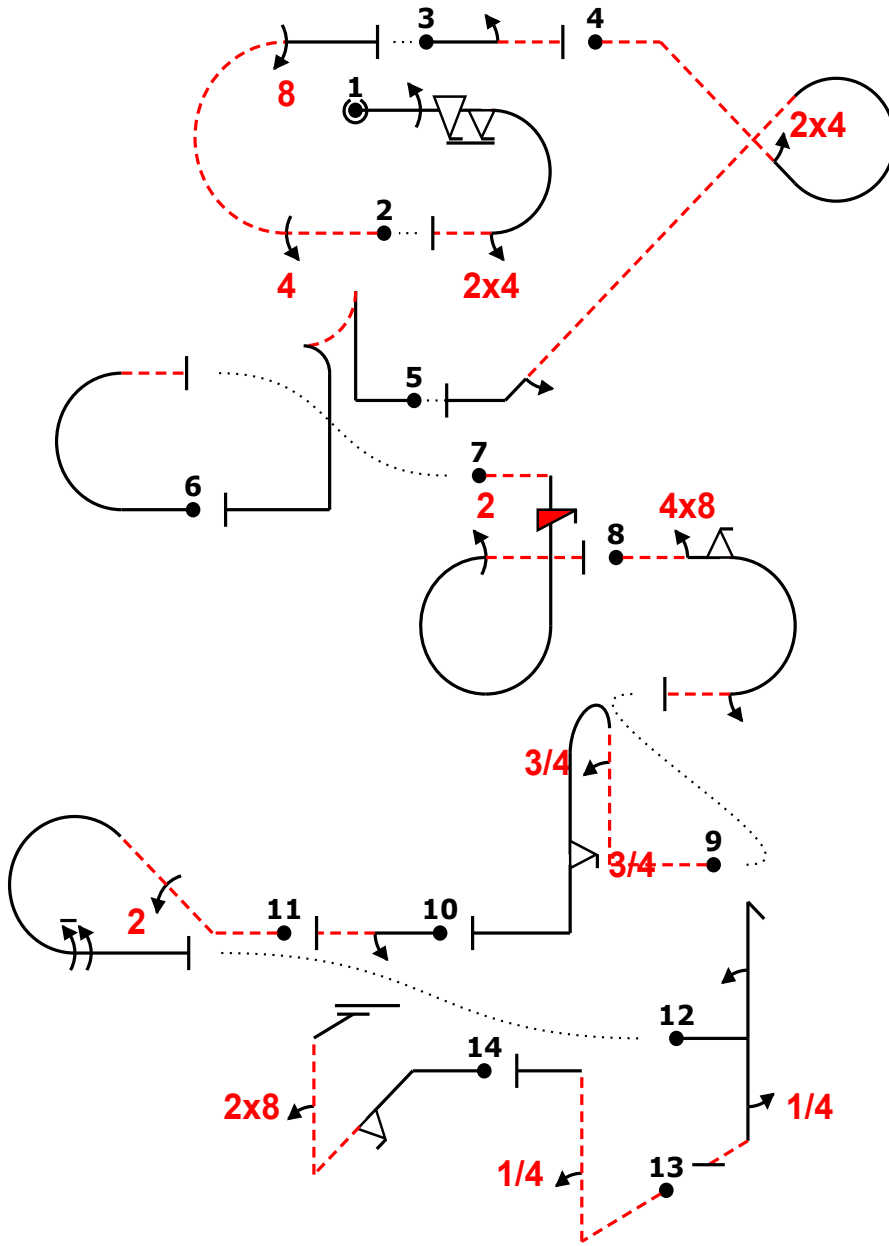

Figure K
316
Total K
346

| | |
|-------------|--------|
| Judges Name | |
| Signature | Number |

| |
|----------|
| Flight # |
|----------|



| Fig | Grade | Pos | Remarks |
|-----|-------|-----|---------|
| 1 | . | | |
| 2 | . | | |
| 3 | . | | |
| 4 | . | | |
| 5 | . | | |
| 6 | . | | |
| 7 | . | | |
| 8 | . | | |
| 9 | . | | |
| 10 | . | | |
| 11 | . | | |
| 12 | . | | |
| 13 | . | | |
| 14 | . | | |

Positioning
30 .

| | | | |
|---------------|--|----------------|--|
| Too Low | | Trg Violation | |
| Too High | | Wing Rocks | |
| Interruptions | | Disqual Fig | |
| Insertions | | Other(note...) | |

"@A" -1% 1,6fa24- (1,0) "@E" 4% -44m,88 (-1,0) "@L" 2- "@J" -1% --24ig.....2 (2,0) "@B" -2% ~~~~~+i
ta "@L" m- (14,6) "@F" -isirp22- "@C" -48;2fa2- (7,10) "@D" -3b3f> "@L" -1% 2- "@G" -~~~~~22rc9+~
~~~~~ (26,5) "@I" 2h4- "@L" > ---v4' "@H" 2fit8^

| Fig 1 A | K  | Fig 2 E | K  | Fig 3 L | K | Fig 4 J | K  | Fig 5 B | K  | Fig 6 L | K | Fig 7 F  | K  | Fig 8 C | K  | Fig 9 D | K  | Fig 10 L | K | Fig 11 G | K  | Fig 12 I | K  | Fig 13 L | K  | Fig 14 H | K  |
|---------|----|---------|----|---------|---|---------|----|---------|----|---------|---|----------|----|---------|----|---------|----|----------|---|----------|----|----------|----|----------|----|----------|----|
| 7.2.4.3 | 6  | 7.2.1.2 | 8  | 1.1.1.3 | 2 | 7.3.4.4 | 15 | 6.2.2.1 | 15 | 7.2.1.1 | 6 | 8.6.1.4  | 12 | 7.2.2.4 | 7  | 8.4.4.2 | 14 | 1.1.1.3  | 2 | 8.5.1.2  | 10 | 5.2.1.3  | 18 | 1.1.7.2  | 12 | 1.2.3.3  | 15 |
| 9.1.3.4 | 8  | 9.4.3.4 | 11 | 9.1.3.2 | 4 | 9.4.4.2 | 5  |         |    |         |   | 9.12.1.4 | 7  | 9.8.3.2 | 7  | 9.1.1.3 | 10 | 9.1.3.2  | 4 | 9.2.2.4  | 11 | 9.1.1.2  | 8  | 9.1.1.1  | 6  | 9.9.4.2  | 11 |
| 9.9.3.6 | 14 | 9.8.3.4 | 15 |         |   | 9.1.4.2 | 4  |         |    |         |   | 9.2.3.4  | 9  | 9.9.3.2 | 11 | 9.9.5.3 | 11 |          |   | 9.1.3.8  | 12 | 9.1.5.1  | 2  |          |    | 9.8.1.1  | 7  |
| 9.4.3.2 | 5  |         |    |         |   |         |    |         |    |         |   |          |    | 9.1.3.2 | 4  |         |    |          |   |          |    |          |    |          |    |          |    |
|         | 33 |         | 34 |         | 6 |         | 24 |         | 15 |         | 6 |          | 28 |         | 29 |         | 35 |          | 6 |          | 33 |          | 28 |          | 6  |          | 33 |

Pilot: Proq B

A/C:

|             |        |
|-------------|--------|
| Judges Name |        |
| Signature   | Number |

|          |
|----------|
| Flight # |
|----------|

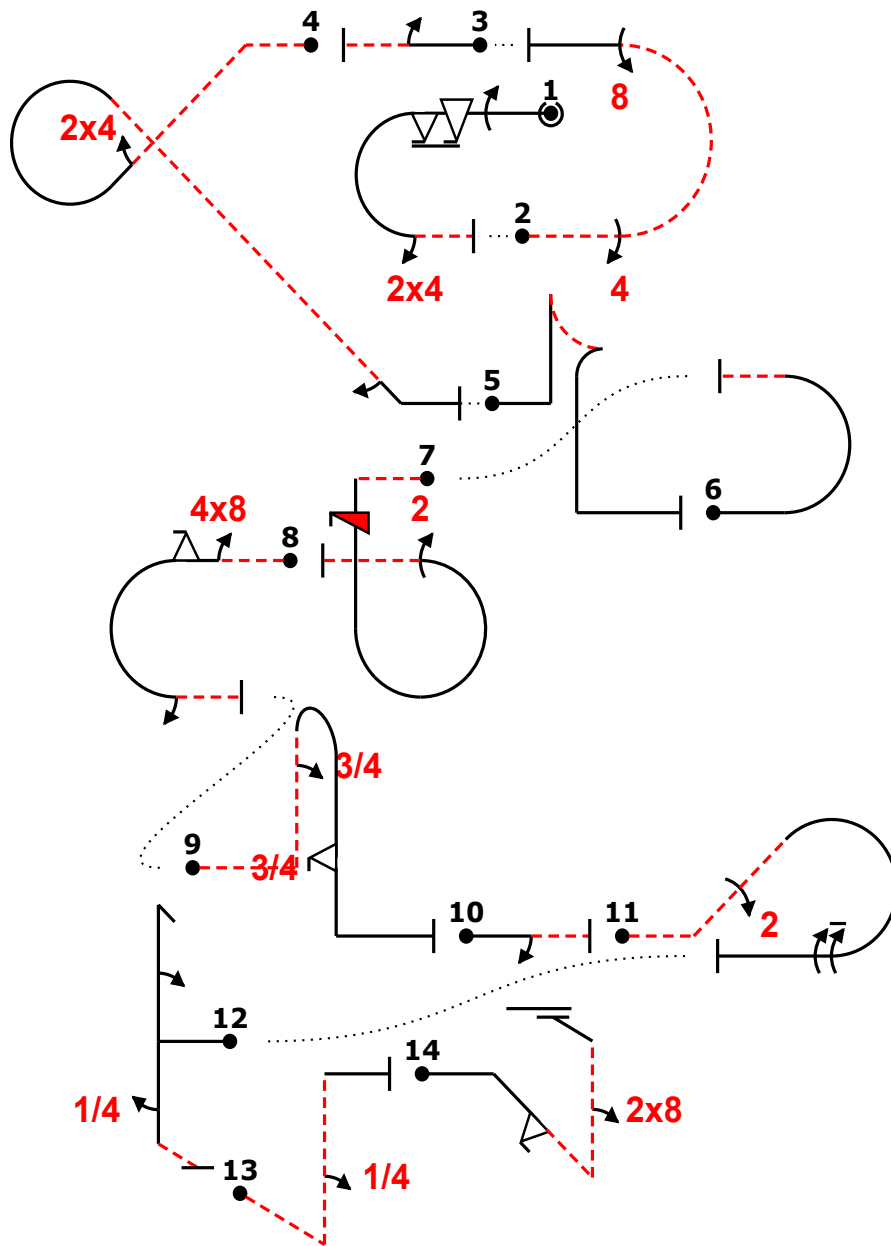
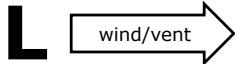

| Fig | Grade | Pos | Remarks |
|-----|-------|-----|---------|
| 1   | .     |     |         |
| 2   | .     |     |         |
| 3   | .     |     |         |
| 4   | .     |     |         |
| 5   | .     |     |         |
| 6   | .     |     |         |
| 7   | .     |     |         |
| 8   | .     |     |         |
| 9   | .     |     |         |
| 10  | .     |     |         |
| 11  | .     |     |         |
| 12  | .     |     |         |
| 13  | .     |     |         |
| 14  | .     |     |         |

|             |    |   |
|-------------|----|---|
| Positioning | 30 | . |
|-------------|----|---|

|               |  |                |  |
|---------------|--|----------------|--|
| Too Low       |  | Trg Violation  |  |
| Too High      |  | Wing Rocks     |  |
| Interruptions |  | Disqual Fig    |  |
| Insertions    |  | Other(note...) |  |

"@A" -1% 1,6fa24- (1,0) "@E" 4% -44m,88 (-1,0) "@L" 2- "@J" -1% --24ig.....2 (2,0) "@B" -2% ~~~~+i  
 ta "@L" m- (14,6) "@F" -isirp22- "@C" -48;2fa2- (7,10) "@D" -3b3f> "@L" -1% 2- "@G" -~~~~~22rc9+~  
 ~~~~~ (26,5) "@I" 2h4- "@L" > --v4' "@H" 2fit8^

| Fig 1 A | K | Fig 2 E | K | Fig 3 L | K | Fig 4 J | K | Fig 5 B | K | Fig 6 L | K | Fig 7 F | K | Fig 8 C | K | Fig 9 D | K | Fig 10 L | K | Fig 11 G | K | Fig 12 I | K | Fig 13 L | K | Fig 14 H | K |
|---------|----|---------|----|---------|---|---------|----|---------|----|---------|---|----------|----|---------|----|---------|----|----------|---|----------|----|----------|----|----------|----|----------|----|
| 7.2.4.3 | 6 | 7.2.1.2 | 8 | 1.1.1.3 | 2 | 7.3.4.4 | 15 | 6.2.2.1 | 15 | 7.2.1.1 | 6 | 8.6.1.4 | 12 | 7.2.2.4 | 7 | 8.4.4.2 | 14 | 1.1.1.3 | 2 | 8.5.1.2 | 10 | 5.2.1.3 | 18 | 1.1.7.2 | 12 | 1.2.3.3 | 15 |
| 9.1.3.4 | 8 | 9.4.3.4 | 11 | 9.1.3.2 | 4 | 9.4.4.2 | 5 | | | | | 9.12.1.4 | 7 | 9.8.3.2 | 7 | 9.1.1.3 | 10 | 9.1.3.2 | 4 | 9.2.2.4 | 11 | 9.1.1.2 | 8 | 9.1.1.1 | 6 | 9.9.4.2 | 11 |
| 9.9.3.6 | 14 | 9.8.3.4 | 15 | | | 9.1.4.2 | 4 | | | | | 9.2.3.4 | 9 | 9.9.3.2 | 11 | 9.9.5.3 | 11 | | | 9.1.3.8 | 12 | 9.1.5.1 | 2 | | | 9.8.1.1 | 7 |
| 9.4.3.2 | 5 | | | | | | | | | | | | | 9.1.3.2 | 4 | | | | | | | | | | | | |
| | 33 | | 34 | | 6 | | 24 | | 15 | | 6 | | 28 | | 29 | | 35 | | 6 | | 33 | | 28 | | 6 | | 33 |

Pilot: Proq B

A/C:

wind/vent ←

