

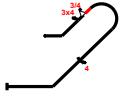

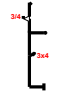

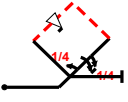





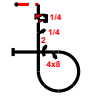

Pilot ID

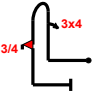
CIVA Unlimited Programme2

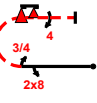
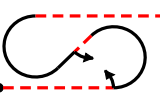
Flight #

No	Symbol	Cat. No.	K	Total K	Grade	Pos	Remarks	Item	K	Grade
1		8.6.1.1 9.10.6.4 9.2.3.8 9.1.3.7 9.4.3.3	11 19 15 11 8	Fig B <b>64</b>	.			Pos.	40	
2		8.4.15.1 9.4.2.3 9.9.2.3 9.4.4.4	12 10 13 11	Fig D <b>46</b>	.			Harm.	0	
3		5.2.1.1 9.9.1.3 9.4.5.3	17 15 8	Fig H <b>40</b>	.			Fig K	454	Total K 494
4		7.4.5.1 9.1.2.1 9.1.2.5 9.9.9.4	15 4 11 13	Fig G <b>43</b>	.			<b>Penalties</b>		
5		1.3.11.1 9.1.4.2	20 4	additional <b>6</b>	.			Too Low		
6		8.6.2.4 9.12.1.5 9.1.5.1 9.8.3.2 9.2.3.4	12 6 2 7 9	Fig E <b>36</b>	.			Too High		
7		8.4.1.1 9.1.1.1	13 6	additional <b>6</b>	.			Interruptions		
8		1.2.5.1 9.1.1.5 9.10.4.4	14 14 13	Fig C <b>41</b>	.			Insertions		
9		8.4.4.2	14	additional <b>6</b>	.			Trg Violation		
10		8.4.1.1 9.4.1.3 9.10.10.3	13 12 15	Fig A <b>40</b>	.			Wing Rocks		
11		5.3.2.1 9.4.2.2 9.1.1.3 9.9.5.3	24 7 10 11	Fig F <b>52</b>	.			Disqual Fig		
12		7.2.4.1 9.8.3.1 9.1.3.3 9.10.3.6 9.4.3.4	8 3 6 16 11	Fig J <b>44</b>	.			Other(note...)		
13		7.5.5.2 9.1.3.2 9.1.4.2	15 4 4	additional <b>6</b>	.			<b>Final Freestyle</b>		
14		2.2.3.2	24	Fig I <b>24</b>	.			Duration	Min	Sec
								<b>Judges Details</b>		
								Signature		
								Name		
								Number		

Pilot

A/C



Pilot ID

CIVA Unlimited Programme2

Flight #

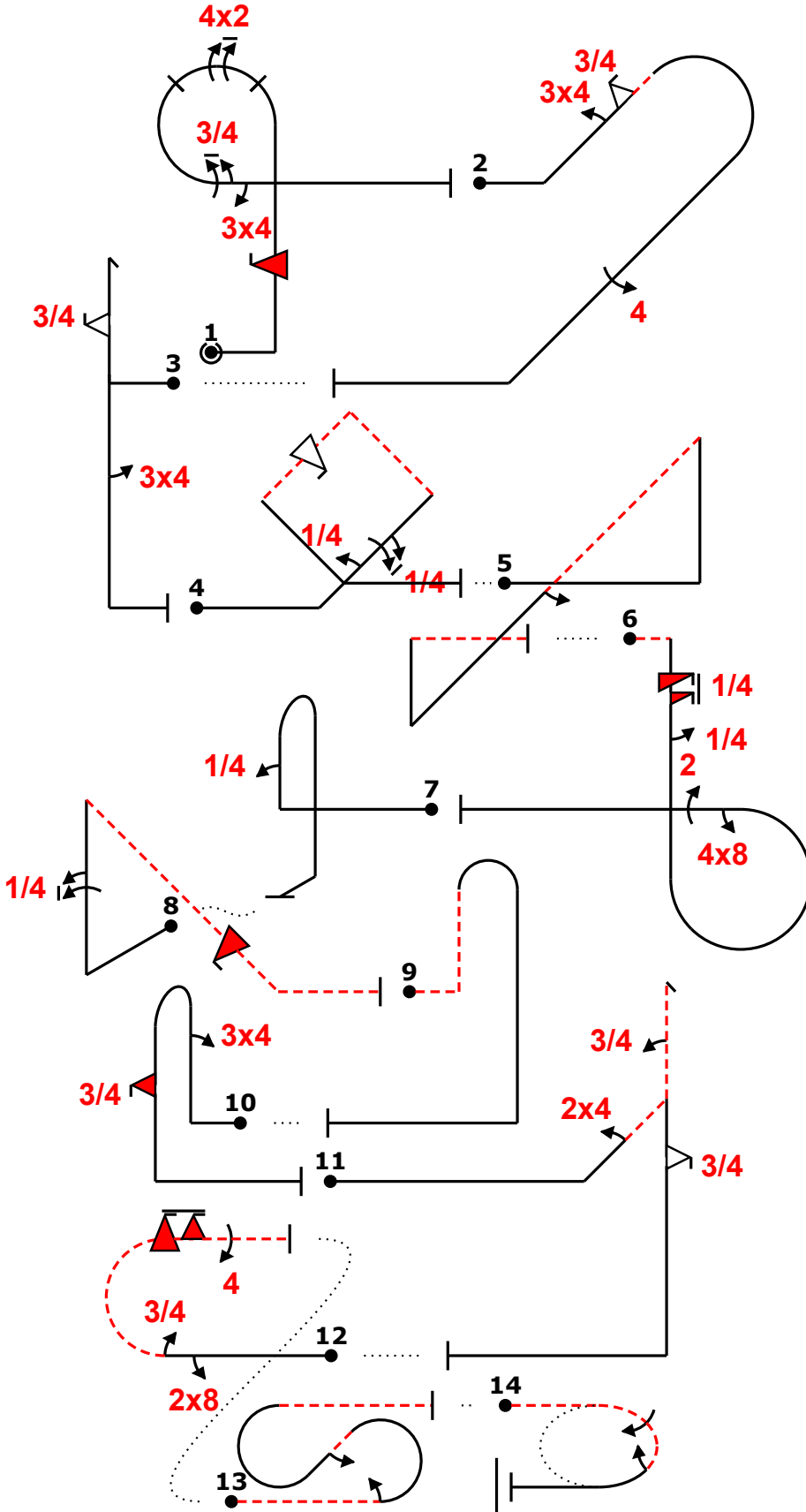
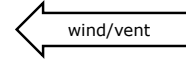

Power			
Fig	Aresti	K	
1 B	8.6.1.1	11	64
	9.10.6.4	19	
	9.2.3.8	15	
	9.1.3.7	11	
	9.4.3.3	8	
2 D	8.4.15.1	12	46
	9.4.2.3	10	
	9.9.2.3	13	
	9.4.4.4	11	
3 H	5.2.1.1	17	40
	9.9.1.3	15	
	9.4.5.3	8	
4 G	7.4.5.1	15	43
	9.1.2.1	4	
	9.1.2.5	11	
	9.9.9.4	13	
5 Add.	1.3.11.1	20	6
	9.1.4.2	4	
6 E	8.6.2.4	12	36
	9.12.1.5	6	
	9.1.5.1	2	
	9.8.3.2	7	
	9.2.3.4	9	
7 Add.	8.4.1.1	13	6
	9.1.1.1	6	
8 C	1.2.5.1	14	41
	9.1.1.5	14	
	9.10.4.4	13	
9 Add.	8.4.4.2	14	6
10 A	8.4.1.1	13	40
	9.4.1.3	12	
	9.10.10.3	15	
11 F	5.3.2.1	24	52
	9.4.2.2	7	
	9.1.1.3	10	
	9.9.5.3	11	
12 J	7.2.4.1	8	44
	9.8.3.1	3	
	9.1.3.3	6	
	9.10.3.6	16	
	9.4.3.4	11	
13 Add.	7.5.5.2	15	6
	9.1.3.2	4	
	9.1.4.2	4	
14 I	2.2.3.2	24	24
<b>Total K = 454</b>			

"@B" . 'if.rp(,42)7,34+++ "@D" 34;3frdb.44...' (-7,0) "@H" 3fh.34...' "@G" 4,5dqf (-1,0) "@L" +++n(..2...) ~~~~ (3,0) 2%  
 "@E" ~~~~5is;4irp'48,22+++ "@L" ~~~~4b'~ (-4,0) "@C" ~~~~+5'k...if ~~~~ "@L" ~~~~b..+++ (-2,0) "@A" ~~~~+,34b~',3if'++~  
 "@F" ~~~~+24dh(3)3f...'+~ (-4,0) "@J" . '8,3m6if,44- (-8,18) "@L" ~~~~3% ~~~~2ac(2)~ (1,0) "@I" ~~~~2j15

Pilot  
A/C



Pilot ID

CIVA Unlimited Programme2

Flight #

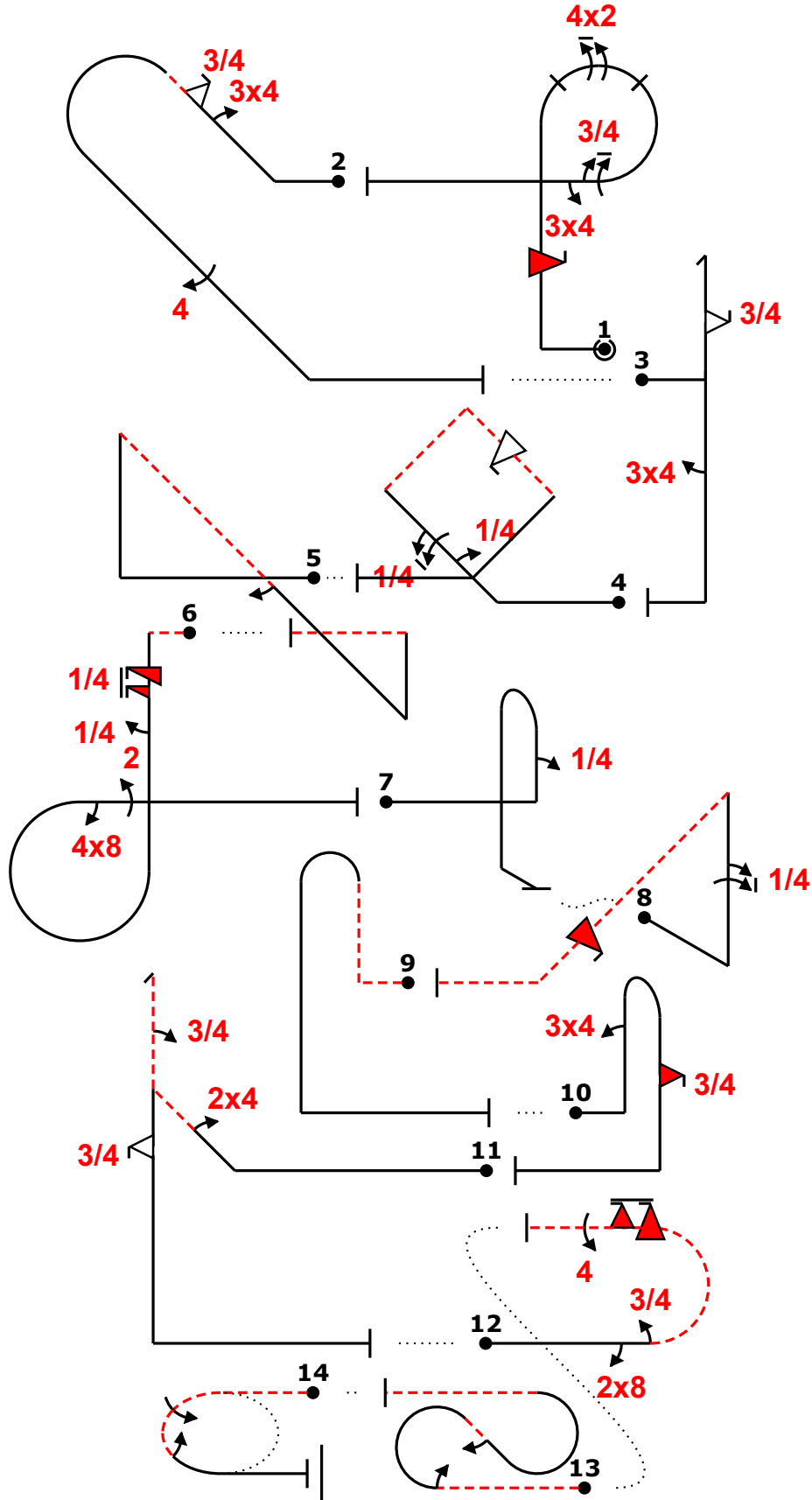
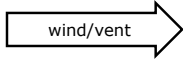

"@B" . 'if.rp(,42)7,34+++ "0D" 34;3frdb.44...' (-7,0) "0H" 3fh.34...' "0G" 4,5dqf (-1,0) "0L" +++n(...2...) (3,0) 2%  
"0E" ~~~5is;4irp'48,22+++ "0L" ~~~4b+' (-4,0) "0C" ~~~+5'k...if~~~~ "0L" ~~~b.+++ (-2,0) "0A" ~~~+34b~~,3if'+~  
"0F" ~~~+24dh(3)3f...'+~ (-4,0) "0J" . '8,3m6if,44- (-8,18) "0L" -3% ~~~2ac(2)~ (1,0) "0I" ~2j15

Pilot  
A/C

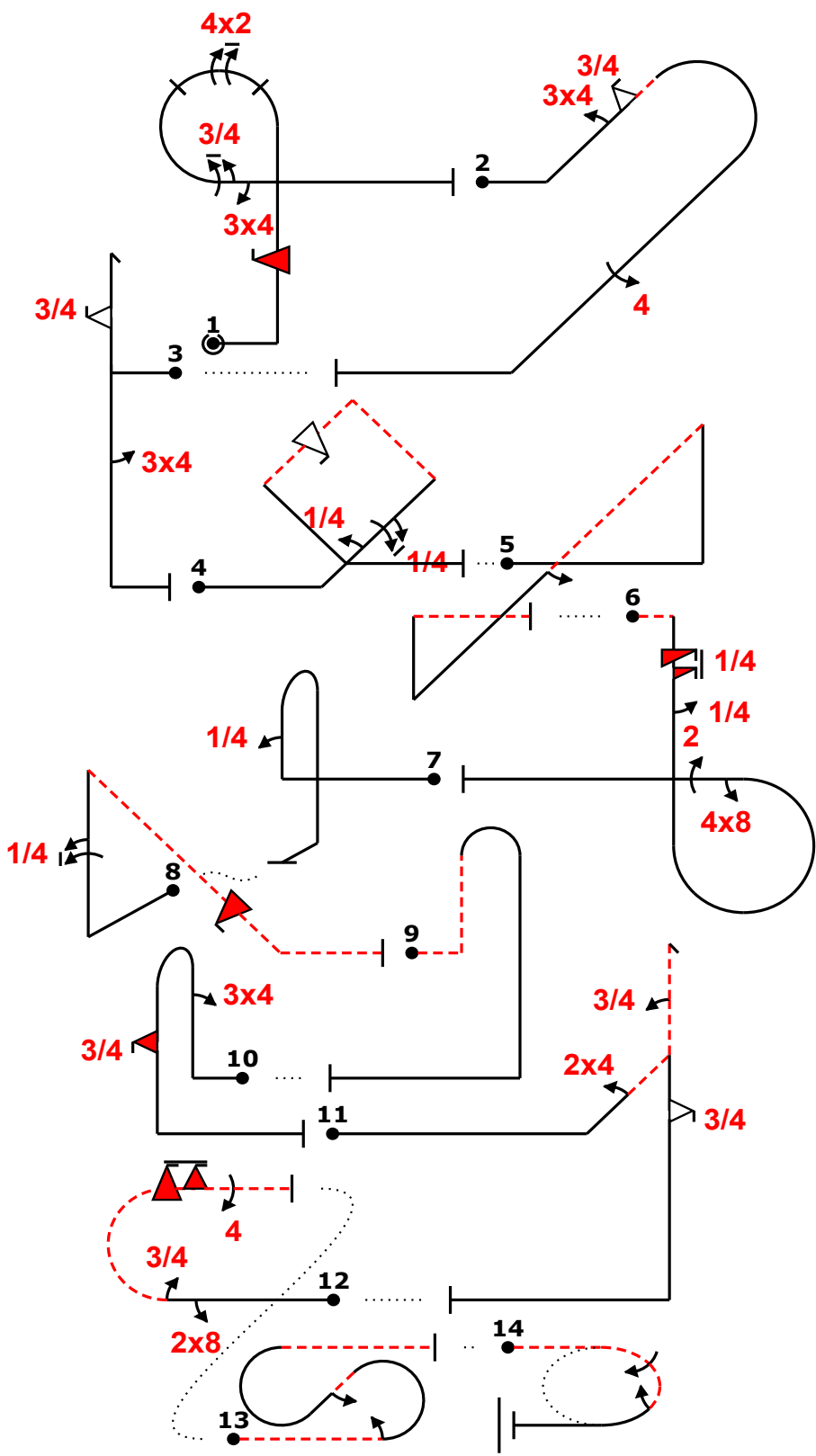
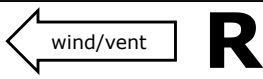

Fig	Grade	Pos	Remarks
1	.		
2	.		
3	.		
4	.		
5	.		
6	.		
7	.		
8	.		
9	.		
10	.		
11	.		
12	.		
13	.		
14	.		

Positioning  
**40** .

Too Low		Trg Violation	
Too High		Wing Rocks	
Interruptions		Disqual Fig	
Insertions		Other(note...)	

```
"@B" . 'if.rp(,42)7,34+++ "eD" 34;3frdb..44...' (-7,0) "@H" 3fh.34...' "@G" 4,5dqf (-1,0) "@L" +++(
.. '2...' ) (3,0) 2% "@B" ~~~~ 5is;4irp'48,22+++ "@L" ~~~~ 4b'+~~~ (-4,0) "@C" ~~~~ +5'k...if~~~~
"@L" ~~~~ -b...+++ (-2,0) "@A" ~~~~ +,34b~~~ ,3if'~~~ "@F" ~~~~ +++24dh(3)3f...'+~~~ (-4,0) "@J" . ' '8,3m6
if,44- (-8,18) "@L" -3% ~~~~ 2ac(2)- (1,0) "@I" -2j15
```

Fig 1 B	K	Fig 2 D	K	Fig 3 H	K	Fig 4 G	K	Fig 5 L	K	Fig 6 E	K	Fig 7 L	K	Fig 8 C	K	Fig 9 L	K	Fig 10 A	K	Fig 11 F	K	Fig 12 J	K	Fig 13 L	K	Fig 14 I	K
8.6.1.1	11	8.4.15.1	12	5.2.1.1	17	7.4.5.1	15	1.3.11.1	20	8.6.2.4	12	8.4.1.1	13	1.2.5.1	14	8.4.4.2	14	8.4.1.1	13	5.3.2.1	24	7.2.4.1	8	7.5.5.2	15	2.2.3.2	24
9.10.6.4	19	9.4.2.3	10	9.9.1.3	15	9.1.2.1	4	9.1.4.2	4	9.12.1.5	6	9.1.1.1	6	9.1.1.5	14			9.4.1.3	12	9.4.2.2	7	9.8.3.1	3	9.1.3.2	4		
9.2.3.8	15	9.9.2.3	13	9.4.5.3	8	9.1.2.5	11			9.1.5.1	2			9.10.4.4	13			9.10.10.3	15	9.1.1.3	10	9.1.3.3	6	9.1.4.2	4		
9.1.3.7	11	9.4.4.4	11			9.9.9.4	13			9.8.3.2	7									9.9.5.3	11	9.10.3.6	16				
9.4.3.3	8									9.2.3.4	9											9.4.3.4	11				
	<b>64</b>		<b>46</b>		<b>40</b>		<b>43</b>		<b>6</b>		<b>36</b>		<b>6</b>		<b>41</b>		<b>6</b>		<b>40</b>		<b>52</b>		<b>44</b>		<b>6</b>		<b>24</b>

Pilot:

A/C:

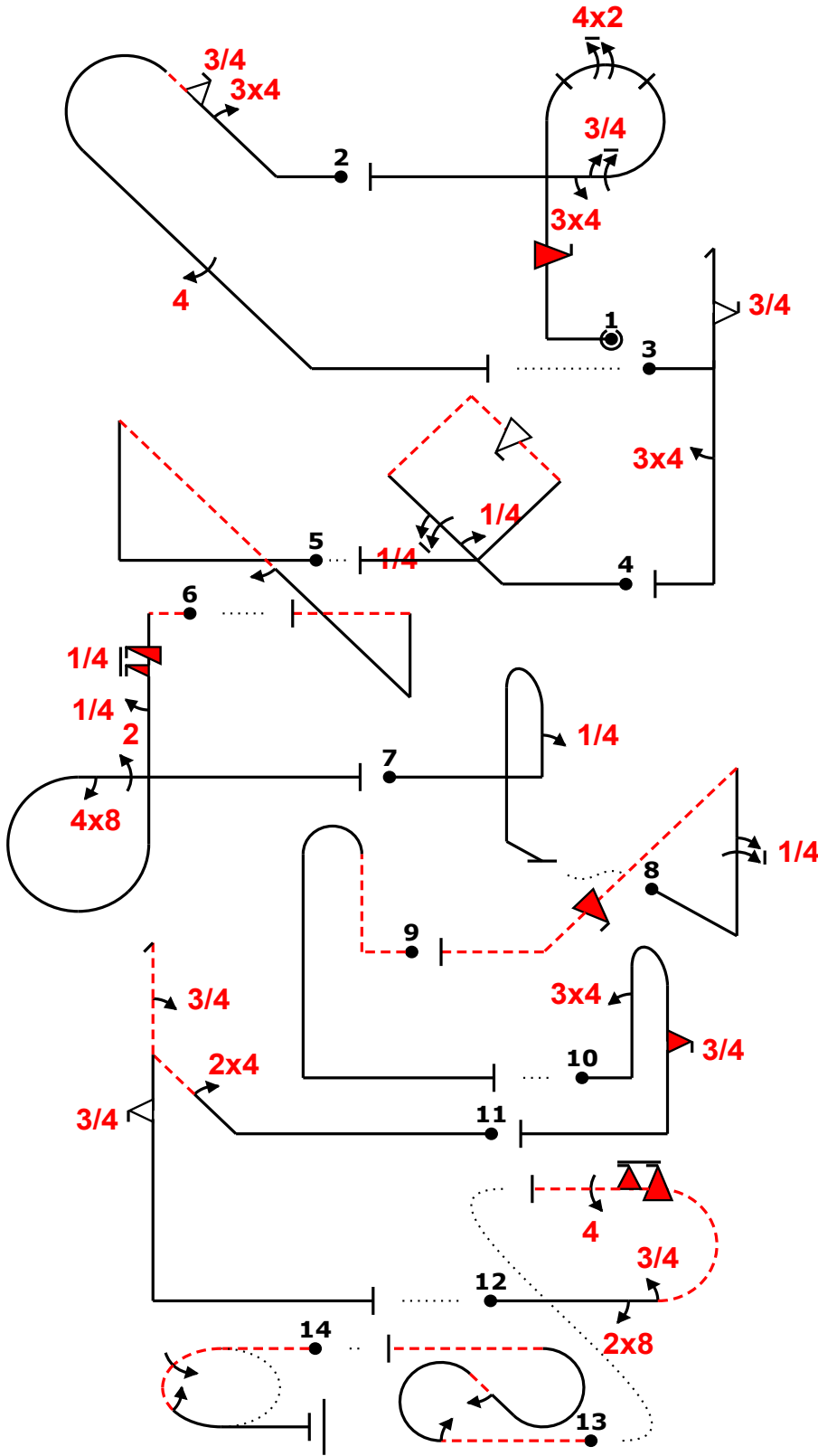
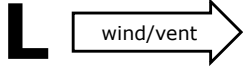

Fig	Grade	Pos	Remarks
1	.		
2	.		
3	.		
4	.		
5	.		
6	.		
7	.		
8	.		
9	.		
10	.		
11	.		
12	.		
13	.		
14	.		

Positioning	
40	.

Too Low		Trg Violation	
Too High		Wing Rocks	
Interruptions		Disqual Fig	
Insertions		Other(note...)	

```
"@B" .'.if.rp(,42)7,34+++ "eD" 34;3frdb..44...' (-7,0) "@H" 3fh.34...' "@G" 4,5dqf (-1,0) "@L" +++n(
..2...)~~~~~ (3,0) 2% "@E" ~~~~ 5is;4irp'48,22+++ "@L" ~+~~~ 4b'+~~~ (-4,0) "@C" ~-+5'k...if~~~~~
"@L" ~~~~ -b...+++ (-2,0) "@A" ~~~~ +,34b~~~ ,3if'~~~ "@F" ~++++24dh(3)3F...'+++++ (-4,0) "@J" .''8,3m6
if,44- (-8,18) "@L" -3% ~~~2ac(2)- (1,0) "@I" -2j15
```

Fig 1 B	K	Fig 2 D	K	Fig 3 H	K	Fig 4 G	K	Fig 5 L	K	Fig 6 E	K	Fig 7 L	K	Fig 8 C	K	Fig 9 L	K	Fig 10 A	K	Fig 11 F	K	Fig 12 J	K	Fig 13 L	K	Fig 14 I	K
8.6.1.1	11	8.4.15.1	12	5.2.1.1	17	7.4.5.1	15	1.3.11.1	20	8.6.2.4	12	8.4.1.1	13	1.2.5.1	14	8.4.4.2	14	8.4.1.1	13	5.3.2.1	24	7.2.4.1	8	7.5.5.2	15	2.2.3.2	24
9.10.6.4	19	9.4.2.3	10	9.9.1.3	15	9.1.2.1	4	9.1.4.2	4	9.12.1.5	6	9.1.1.1	6	9.1.1.5	14			9.4.1.3	12	9.4.2.2	7	9.8.3.1	3	9.1.3.2	4		
9.2.3.8	15	9.9.2.3	13	9.4.5.3	8	9.1.2.5	11			9.1.5.1	2			9.10.4.4	13			9.10.10.3	15	9.1.1.3	10	9.1.3.3	6	9.1.4.2	4		
9.1.3.7	11	9.4.4.4	11			9.9.9.4	13			9.8.3.2	7									9.9.5.3	11	9.10.3.6	16				
9.4.3.3	8									9.2.3.4	9											9.4.3.4	11				
	<b>64</b>		<b>46</b>		<b>40</b>		<b>43</b>		<b>6</b>		<b>36</b>		<b>6</b>		<b>41</b>		<b>6</b>		<b>40</b>		<b>52</b>		<b>44</b>		<b>6</b>	<b>24</b>	

Pilot:

A/C:

wind/vent ←

