

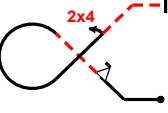
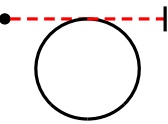
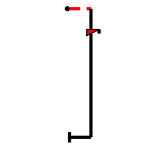
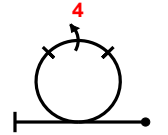
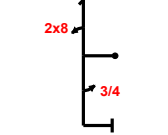
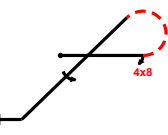
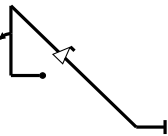
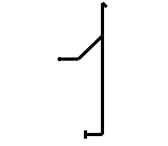
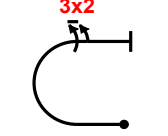
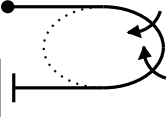

Pilot ID

Flight #

SAA Intermediate Known Compulsory

No	Symbol	Cat. No.	K	Total K	Grade	Pos	Remarks	Item	K	Grade
1		7.3.4.1 9.9.2.2 9.4.2.2	16 13 7	36	.			Pos.	25	
								Harm.	0	
2		7.4.1.4	11	11	.			Fig K	Total K	
								232	257	
3		1.1.7.4 9.12.1.4	9 7	16	.			Penalties		
								Too Low		
4		7.4.1.1 9.4.3.4	10 11	21	.			Too High		
								Interruptions		
5		5.2.1.1 9.8.1.1 9.1.5.3	17 7 6	30	.			Insertions		
								Trg Violation		
6		8.5.7.1 9.8.3.2 9.1.4.4	12 7 8	27	.			Wing Rocks		
								Disqual Fig		
7		5.2.1.1 9.8.1.1 9.1.5.3	17 7 6	30	.			Other(note...)		
								Final Freestyle		
8		7.4.1.1 9.4.3.4	10 11	21	.			Duration	Min	Sec
9		8.5.7.1 9.8.3.2 9.1.4.4	12 7 8	27	.			Judges Details		
								Signature		
10		7.4.1.1 9.4.3.4	10 11	21	.			Name		
								Number		

Pilot

A/C



Pilot ID

SAA Intermediate Known Compulsory

Flight #

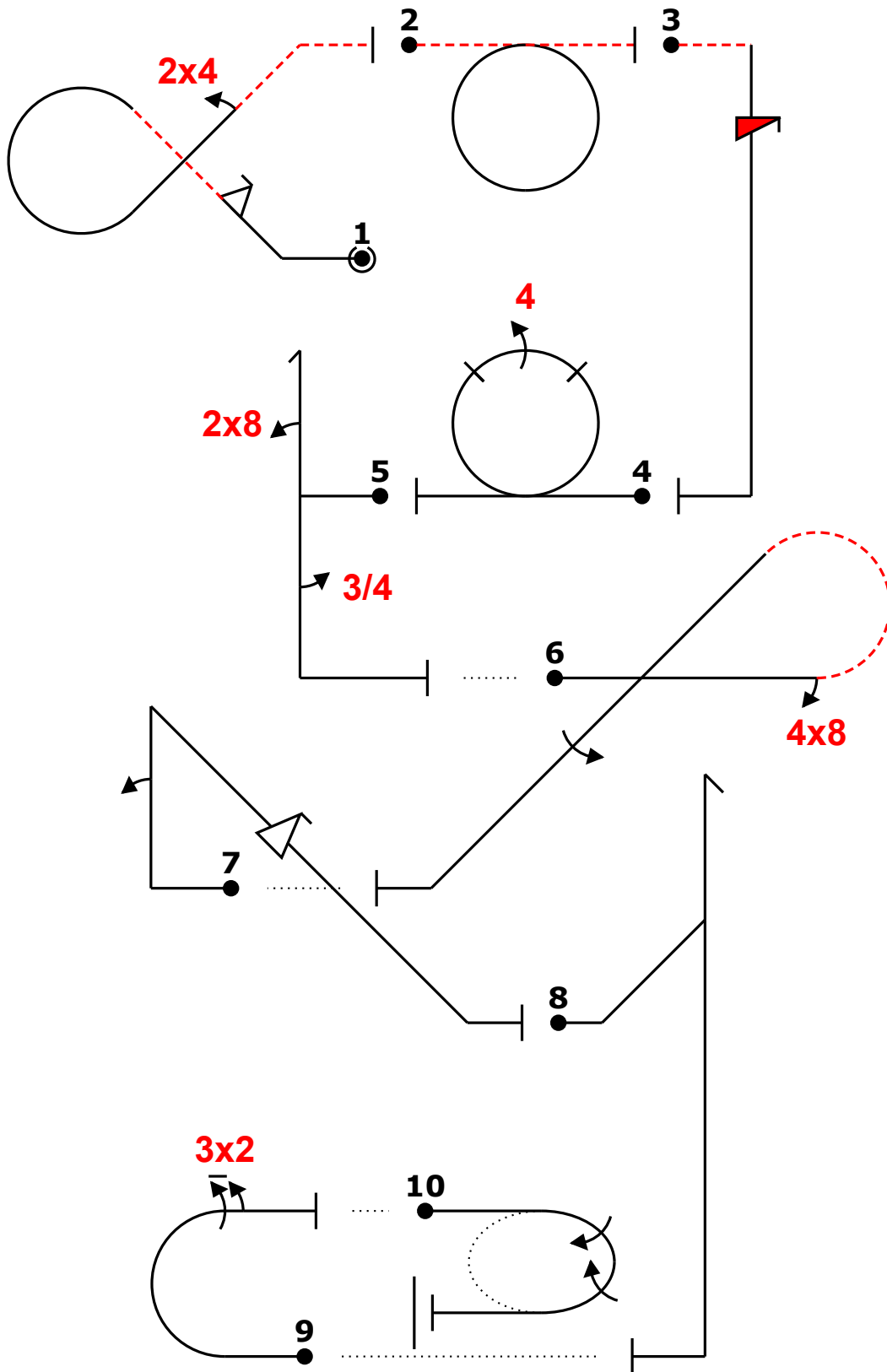
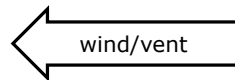

Power			
Fig	Aresti	K	
1	7.3.4.1	16	36
	9.9.2.2	13	
	9.4.2.2	7	
2	7.4.1.4	11	11
3	1.1.7.4	9	16
	9.12.1.4	7	
4	7.4.1.1	10	21
	9.4.3.4	11	
5	5.2.1.1	17	30
	9.8.1.1	7	
	9.1.5.3	6	
6	8.5.7.1	12	27
	9.8.3.2	7	
	9.1.4.4	8	
7	1.2.6.1	14	33
	9.1.1.2	8	
	9.9.4.4	11	
8	5.3.1.1	18	18
9	7.2.2.1	6	18
	9.2.3.6	12	
10	2.2.5.1	22	22
Total K = 232			

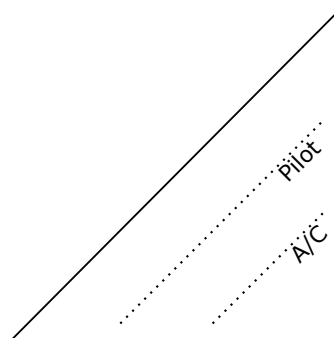



Pilot ID

Flight #

SAA Intermediate Known Compulsory

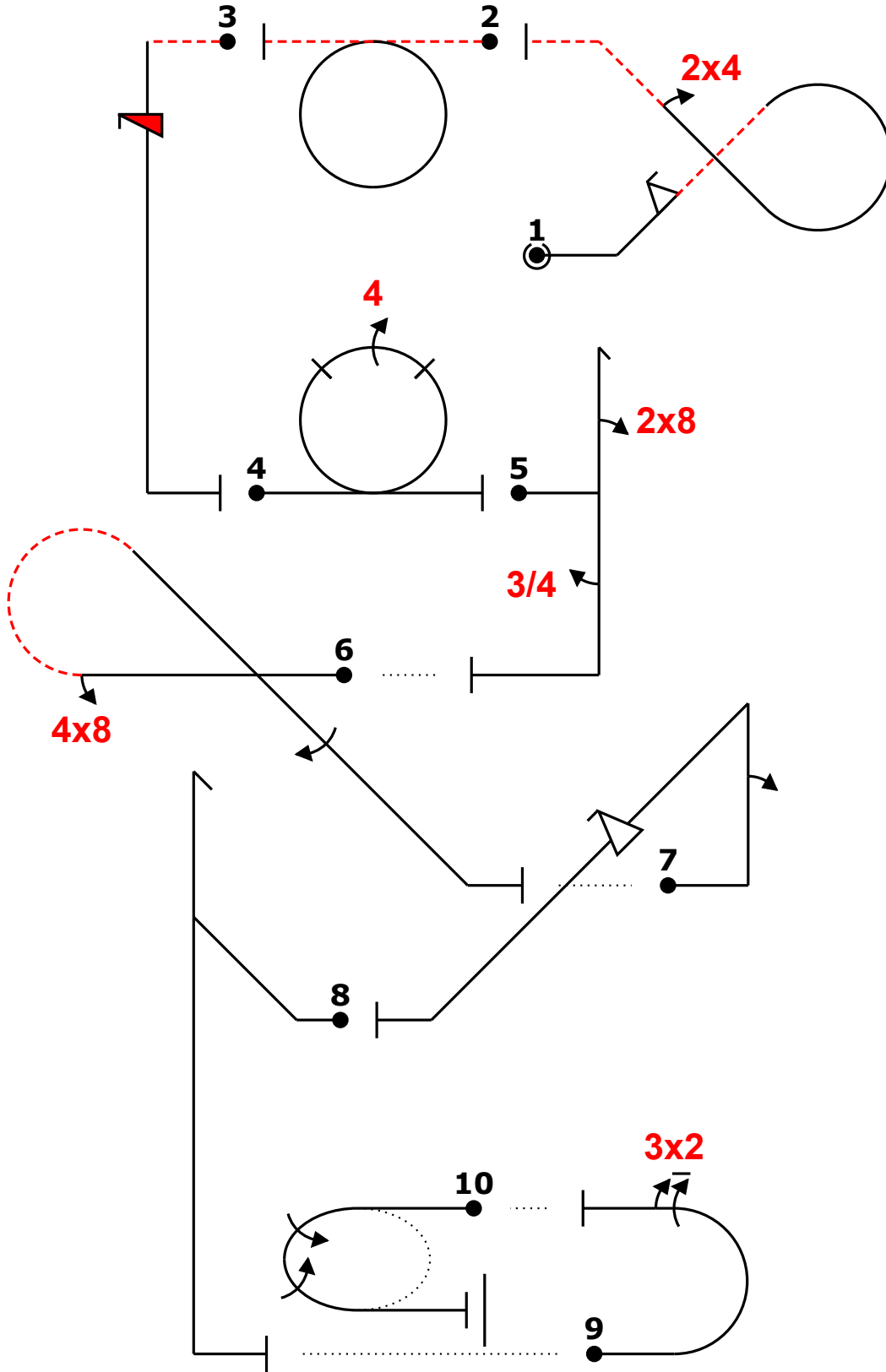
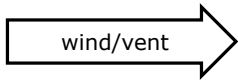

Pilot.....
A/C.....

wind/vent ← **R**

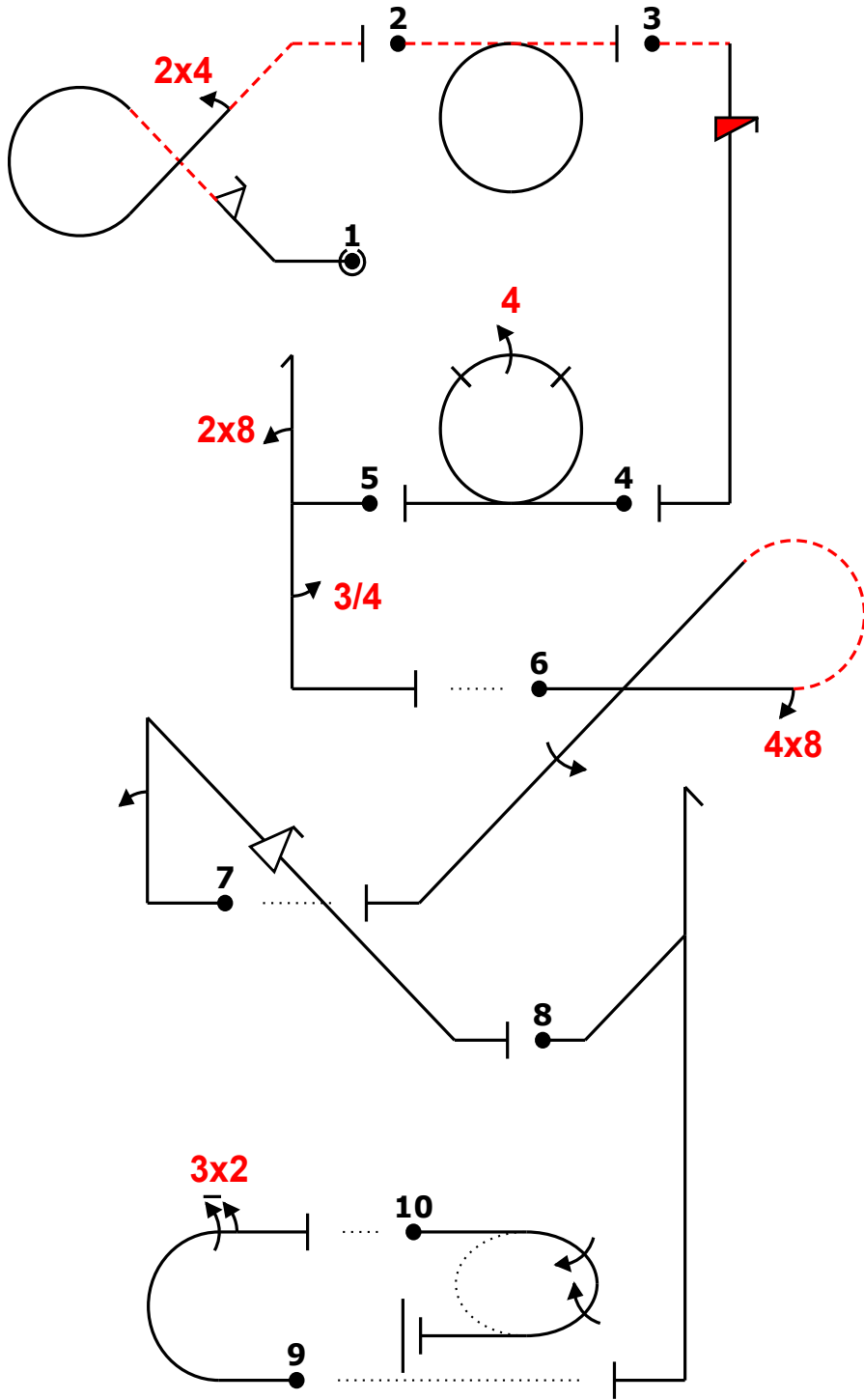

Fig	Grade	Pos	Remarks
1	.		
2	.		
3	.		
4	.		
5	.		
6	.		
7	.		
8	.		
9	.		
10	.		

Positioning
25 .

Too Low		Trg Violation	
Too High		Wing Rocks	
Interruptions		Disqual Fig	
Insertions		Other(note...)	

ed /~~~~,2f.'g24.- -io- -ivis.....' o44 8h'3.+ (3,0) ,48c....1''+ (-4,0) 2k''f..+'' ~dh..... (-14,0) m32 (2,0) 2j2

Fig 1	K	Fig 2	K	Fig 3	K	Fig 4	K	Fig 5	K	Fig 6	K	Fig 7	K	Fig 8	K	Fig 9	K	Fig 10	K
7.3.4.1	16	7.4.1.4	11	1.1.7.4	9	7.4.1.1	10	5.2.1.1	17	8.5.7.1	12	1.2.6.1	14	5.3.1.1	18	7.2.2.1	6	2.2.5.1	22
9.9.2.2	13			9.12.1.4	7	9.4.3.4	11	9.8.1.1	7	9.8.3.2	7	9.1.1.2	8			9.2.3.6	12		
9.4.2.2	7							9.1.5.3	6	9.1.4.4	8	9.9.4.4	11						
	36		11		16		21		30		27		33		18		18		22

Pilot:

A/C:

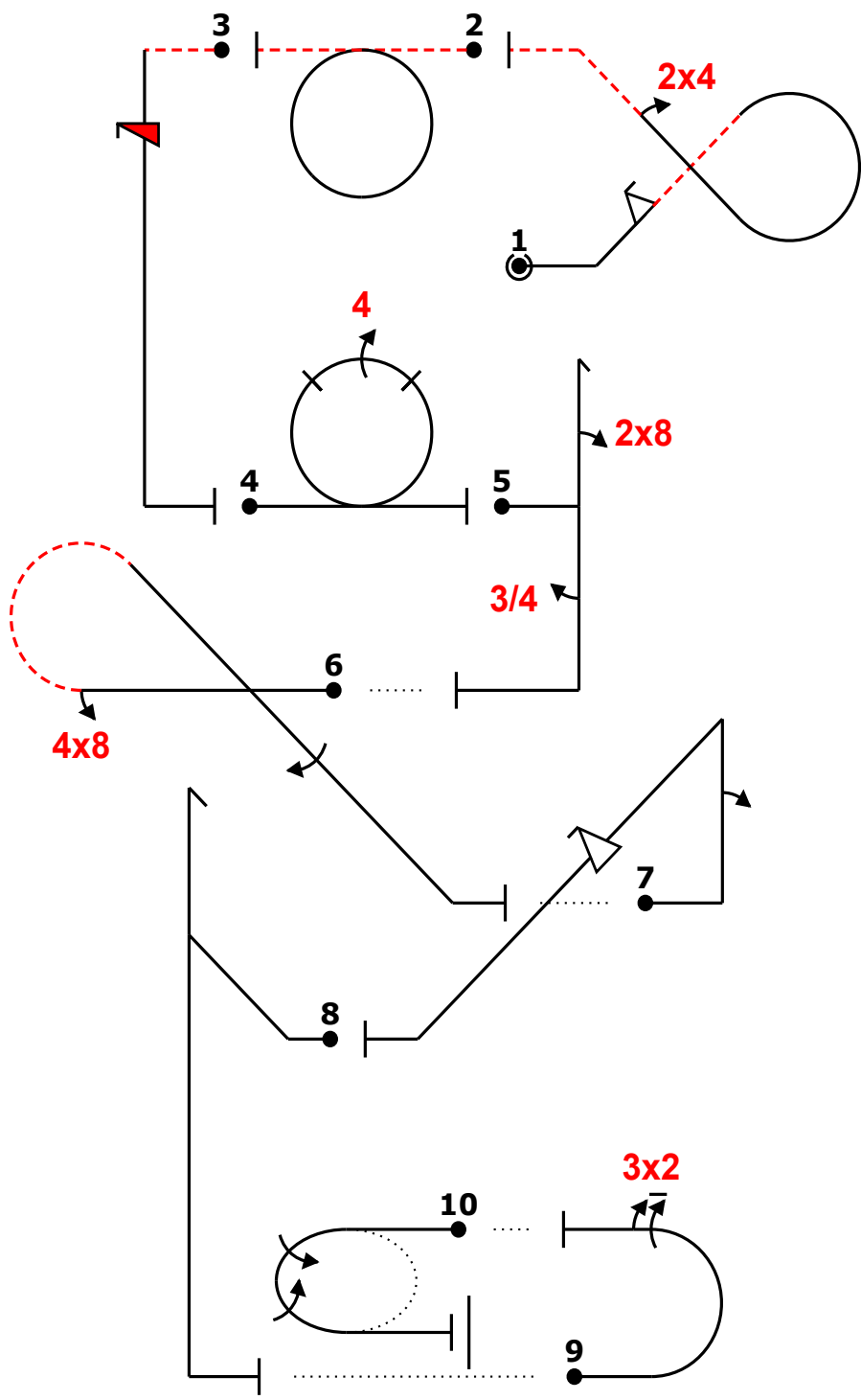
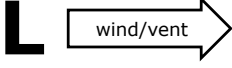

Fig	Grade	Pos	Remarks
1	.		
2	.		
3	.		
4	.		
5	.		
6	.		
7	.		
8	.		
9	.		
10	.		

Positioning **25** .

Too Low		Trg Violation	
Too High		Wing Rocks	
Interruptions		Disqual Fig	
Insertions		Other(note...)	

ed /~~~~,2f.'g24.- -io- -ivis.....' o44 8h'3.+ (3,0) ,48c....1''+ (-4,0) 2k''f..+''~+dh..... (-14,0) m32 (2,0) 2j2

Fig 1	K	Fig 2	K	Fig 3	K	Fig 4	K	Fig 5	K	Fig 6	K	Fig 7	K	Fig 8	K	Fig 9	K	Fig 10	K
7.3.4.1	16	7.4.1.4	11	1.1.7.4	9	7.4.1.1	10	5.2.1.1	17	8.5.7.1	12	1.2.6.1	14	5.3.1.1	18	7.2.2.1	6	2.2.5.1	22
9.9.2.2	13			9.12.1.4	7	9.4.3.4	11	9.8.1.1	7	9.8.3.2	7	9.1.1.2	8			9.2.3.6	12		
9.4.2.2	7							9.1.5.3	6	9.1.4.4	8	9.9.4.4	11						
	36		11		16		21		30		27		33		18		18		22

Pilot:

A/C:

