



Pilot ID

Flight #

SAA Intermediate UK 1

No	Symbol	Cat. No.	K	Total K	Grade	Pos	Remarks	Item	K	Grade
1		1.1.7.4 9.12.1.4	9 7	16 SF 3	.			Pos.	25	
2		7.2.2.1 9.9.3.2	6 11	17 SF 4	.			Fig K		Total K
								236		261
3		2.2.5.1	22	22 SF 2	.			Penalties		
								Too Low		
								Too High		
								Interruptions		
								Insertions		
								Trg Violation		
								Wing Rocks		
								Disqual Fig		
								Other(note...)		
4		8.4.1.1 9.1.5.1	13 2	15 SF 7	.			Final Freestyle		
								Duration	Min	Sec
5		1.2.6.1 9.8.1.1 9.9.4.4	14 7 11	32 SF 4	.			Judges Details		
								Signature		
								Name		
								Number		
6		5.3.2.1 9.1.2.2 9.4.5.2	24 6 5	35 SF 5	.					
7		7.4.1.1 9.4.3.4	10 11	21 SF 7	.					
8		8.5.4.1 9.8.2.2 9.1.3.2	11 9 4	24 SF 7	.					
9		8.4.2.2	17	17 SF 7	.					
10		7.3.2.1 9.1.2.6 9.2.2.4	14 12 11	37 SF 7	.					

Pilot

A/C



Pilot ID

SAA Intermediate UK 1

Flight #

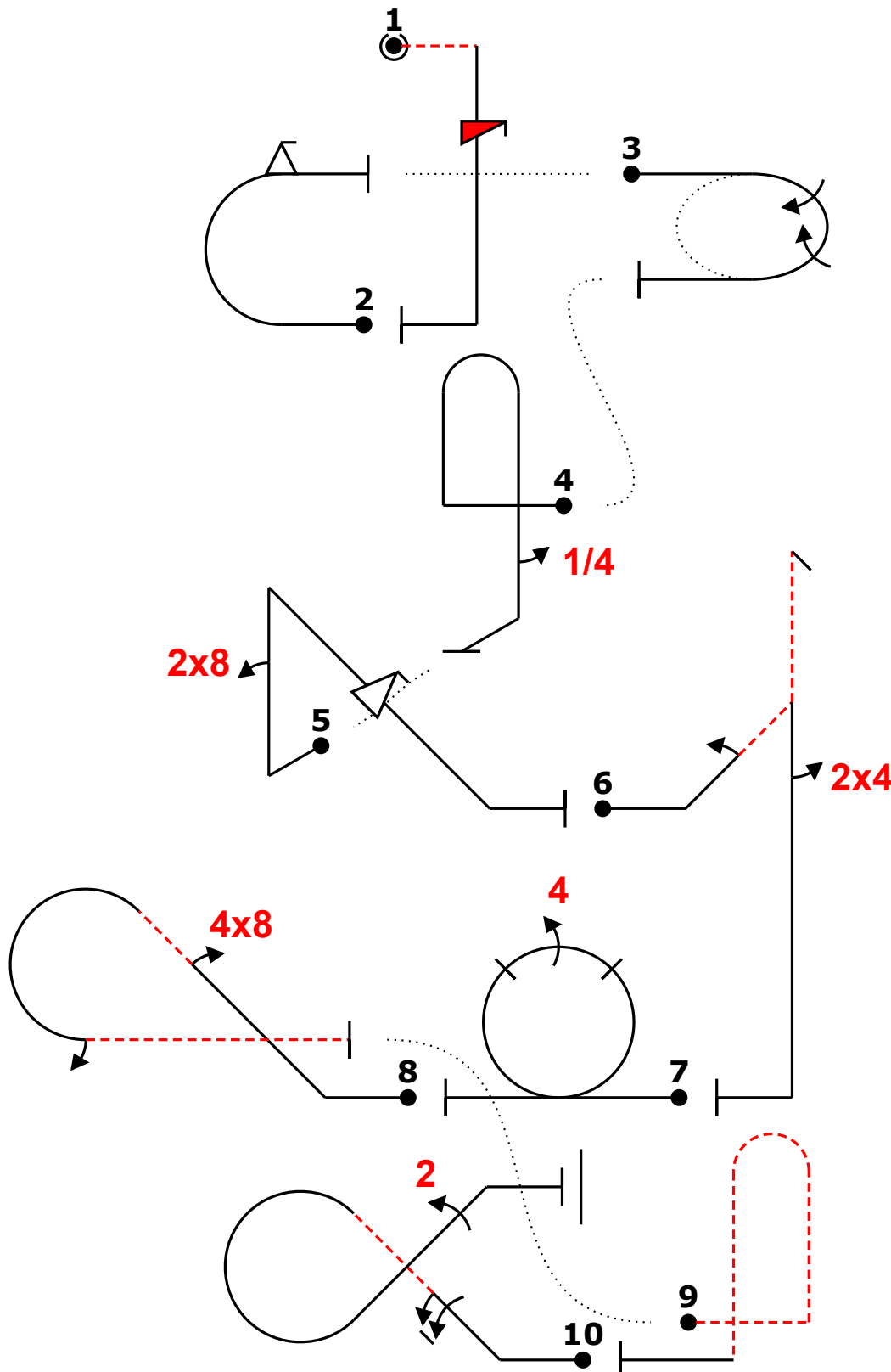
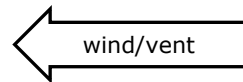

Power			
Fig	Aresti	K	
1	1.1.7.4 9.12.1.4	9 7	16
2	7.2.2.1 9.9.3.2	6 11	17
3	2.2.5.1	22	22
4	8.4.1.1 9.1.5.1	13 2	15
5	1.2.6.1 9.8.1.1 9.9.4.4	14 7 11	32
6	5.3.2.1 9.1.2.2 9.4.5.2	24 6 5	35
7	7.4.1.1 9.4.3.4	10 11	21
8	8.5.4.1 9.8.2.2 9.1.3.2	11 9 4	24
9	8.4.2.2	17	17
10	7.3.2.1 9.1.2.6 9.2.2.4	14 12 11	37
Total K = 236			

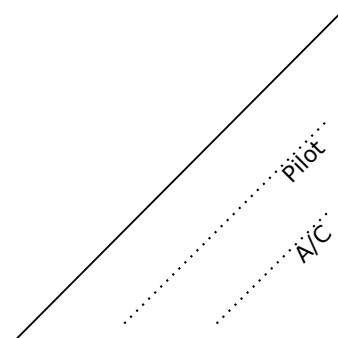



Pilot ID

SAA Intermediate UK 1

Flight #

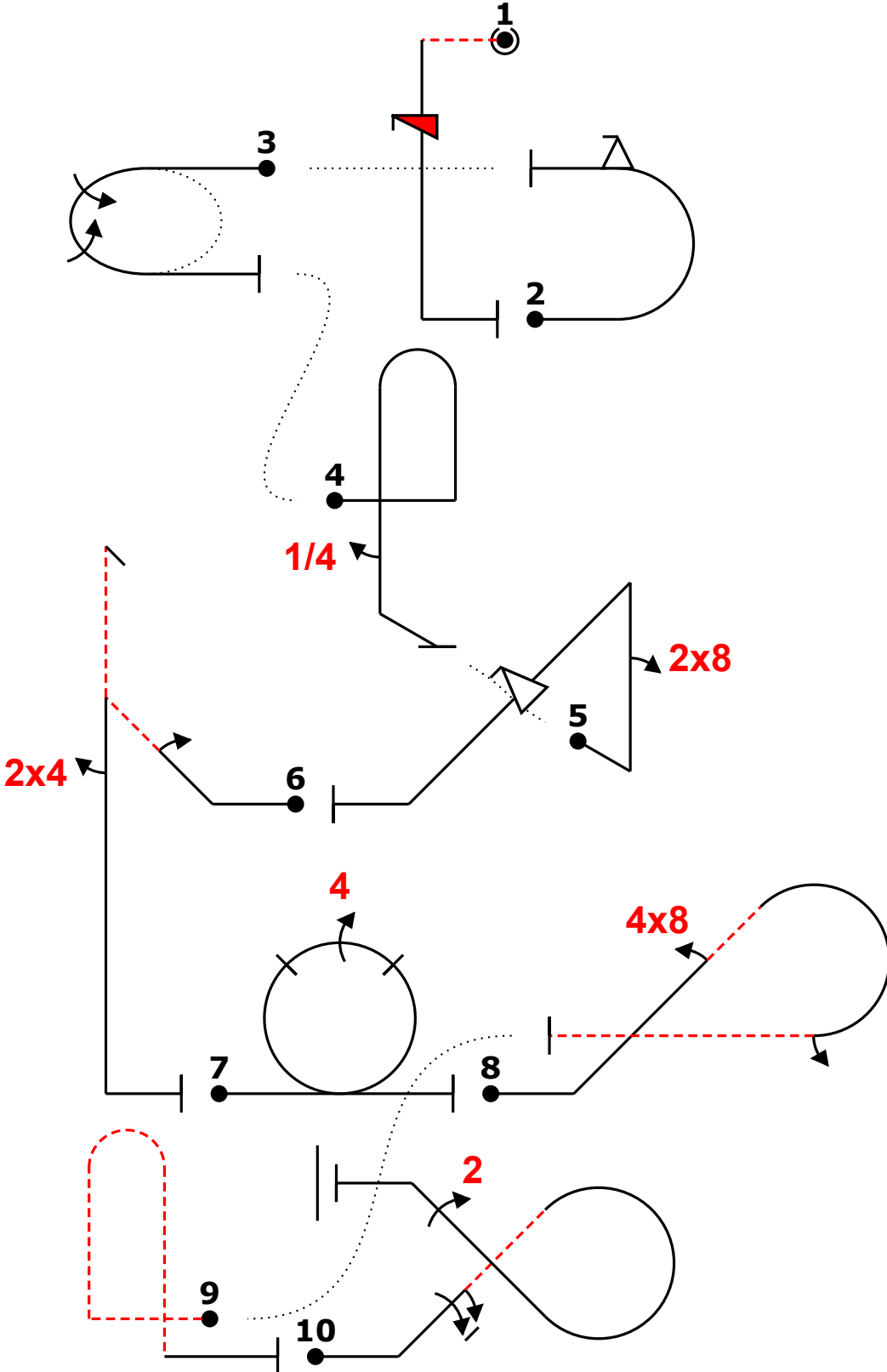
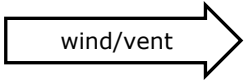

Power			
Fig	Aresti	K	
1	1.1.7.4 9.12.1.4	9 7	16
2	7.2.2.1 9.9.3.2	6 11	17
3	2.2.5.1	22	22
4	8.4.1.1 9.1.5.1	13 2	15
5	1.2.6.1 9.8.1.1 9.9.4.4	14 7 11	32
6	5.3.2.1 9.1.2.2 9.4.5.2	24 6 5	35
7	7.4.1.1 9.4.3.4	10 11	21
8	8.5.4.1 9.8.2.2 9.1.3.2	11 9 4	24
9	8.4.2.2	17	17
10	7.3.2.1 9.1.2.6 9.2.2.4	14 12 11	37
Total K = 236			

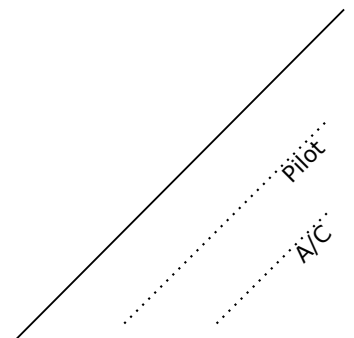

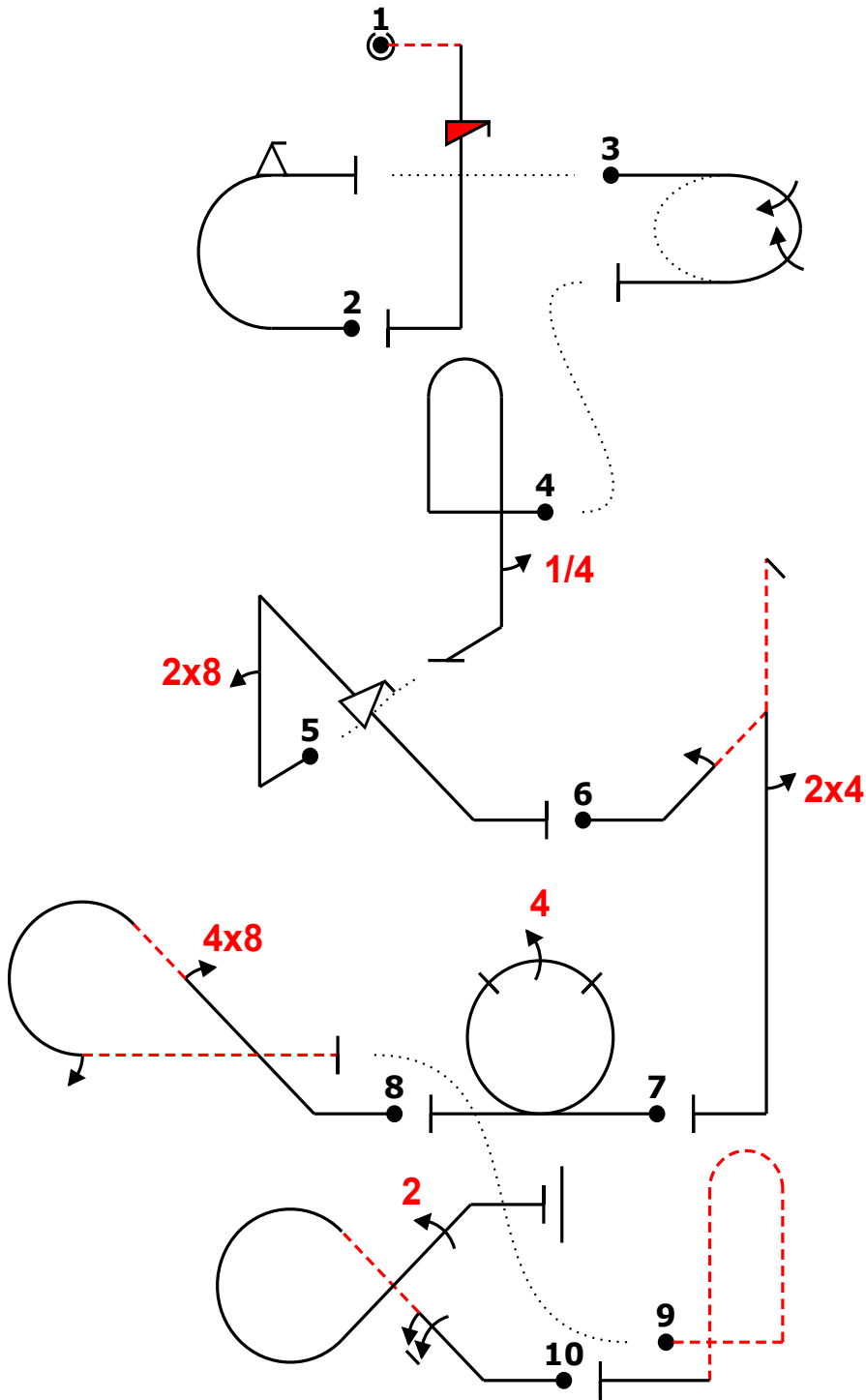

Fig	Grade	Pos	Remarks
1	.		
2	.		
3	.		
4	.		
5	.		
6	.		
7	.		
8	.		
9	.		
10	.		

Positioning **25** .

Too Low		Trg Violation	
Too High		Wing Rocks	
Interruptions		Disqual Fig	
Insertions		Other(note...)	

-ivis.. m2f (10,0) 2j2 (0,12) ``b.4+` (-4,3) 8kf> 2dh24..... o44 ,48rc,2- (14,15) -pb ~~~6.'g22

Fig 1	K	Fig 2	K	Fig 3	K	Fig 4	K	Fig 5	K	Fig 6	K	Fig 7	K	Fig 8	K	Fig 9	K	Fig 10	K
1.1.7.4	9	7.2.2.1	6	2.2.5.1	22	8.4.1.1	13	1.2.6.1	14	5.3.2.1	24	7.4.1.1	10	8.5.4.1	11	8.4.2.2	17	7.3.2.1	14
9.12.1.4	7	9.9.3.2	11			9.1.5.1	2	9.8.1.1	7	9.1.2.2	6	9.4.3.4	11	9.8.2.2	9			9.1.2.6	12
								9.9.4.4	11	9.4.5.2	5			9.1.3.2	4			9.2.2.4	11
SF 3	16	SF 4	17	SF 2	22	SF 7	15	SF 4	32	SF 5	35	SF 7	21	SF 7	24	SF 7	17	SF 7	37

Pilot:

A/C:

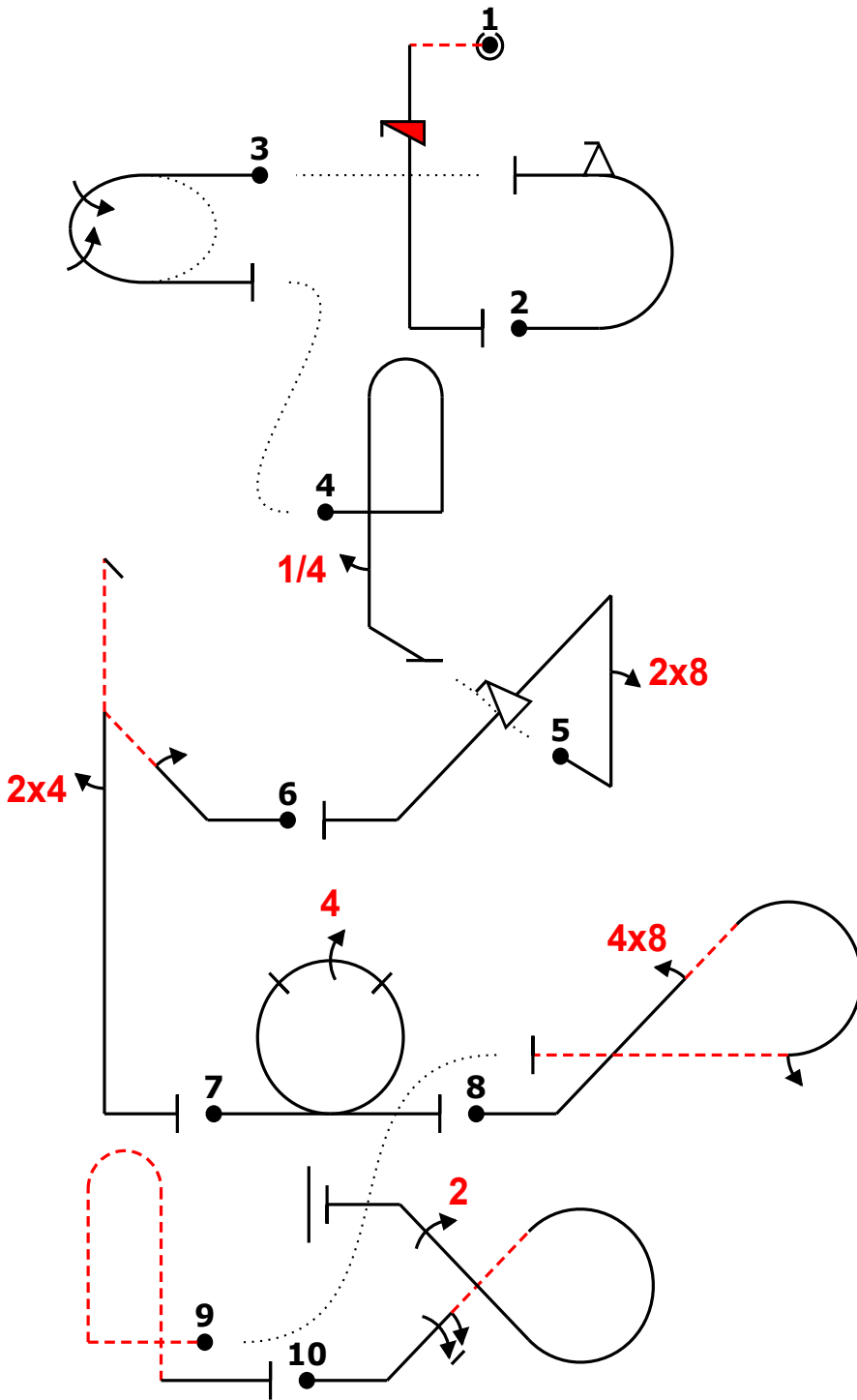
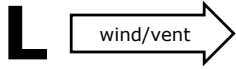

Fig	Grade	Pos	Remarks
1	.		
2	.		
3	.		
4	.		
5	.		
6	.		
7	.		
8	.		
9	.		
10	.		

Positioning
25

Too Low		Trg Violation	
Too High		Wing Rocks	
Interruptions		Disqual Fig	
Insertions		Other(note...)	

-ivis.. m2f (10,0) 2j2 (0,12) ``b.4+` (-4,3) 8kf> 2dh24..... o44 ,48rc,2- (14,15) -pb ````6.'g22

Fig 1	K	Fig 2	K	Fig 3	K	Fig 4	K	Fig 5	K	Fig 6	K	Fig 7	K	Fig 8	K	Fig 9	K	Fig 10	K
1.1.7.4	9	7.2.2.1	6	2.2.5.1	22	8.4.1.1	13	1.2.6.1	14	5.3.2.1	24	7.4.1.1	10	8.5.4.1	11	8.4.2.2	17	7.3.2.1	14
9.12.1.4	7	9.9.3.2	11			9.1.5.1	2	9.8.1.1	7	9.1.2.2	6	9.4.3.4	11	9.8.2.2	9			9.1.2.6	12
								9.9.4.4	11	9.4.5.2	5			9.1.3.2	4			9.2.2.4	11
SF 3	16	SF 4	17	SF 2	22	SF 7	15	SF 4	32	SF 5	35	SF 7	21	SF 7	24	SF 7	17	SF 7	37

Pilot:

A/C:

wind/vent

